

# Workshop manual

BPW ECO Disc TS2 disc brake



# Contents

## BPW ECO Disc TS2 disc brake TS2 3709, TS2 4309

Valid: 01/06/2021

Subject to change without notice.

Current versions and additional information can be found online at [www.bpw.de](http://www.bpw.de).

### Contents

⊙ 1.	<b>Product identification</b> .....	<b>Page 3</b>
⊙ 2.	<b>Safety regulations, safety information</b> .....	<b>Page 4</b>
	2.1 Safety regulations	Page 4
	2.2 Safety information	Page 5
⊙ 3.	<b>Exploded view / name</b> .....	<b>Page 6</b>
⊙ 4.	<b>Tightening torques</b> .....	<b>Page 7</b>
⊙ 5.	<b>Special tools</b> .....	<b>Page 8</b>
⊙ 6.	<b>Maintenance</b> .....	<b>Page 13</b>
⊙ 7.	<b>Structure and function</b> .....	<b>Page 20</b>
	7.1 Applying the brake	Page 20
	7.2 Releasing the brake	Page 20
	7.3 Adjustment	Page 20
	7.4 Resetting	Page 21
	7.5 Brake cylinder	Page 21
⊙ 8.	<b>Changing the brake linings</b> .....	<b>Page 22</b>
	8.1 Resetting the threaded sleeve	Page 22
	8.2 Adjusting the clearance	Page 26
⊙ 9.	<b>Disassembly / assembly of the brake caliper</b> .....	<b>Page 28</b>
	9.1 Removing the brake caliper	Page 28
	9.2 Installing the brake caliper	Page 29
⊙ 10.	<b>Changing the bellow with pressure plate</b> .....	<b>Page 33</b>
⊙ 11.	<b>Overhauling the brake caliper guide</b> .....	<b>Page 36</b>
	11.1 Replacing the bellow (fixed and floating bearing)	Page 36
	11.2 Replacing the guide bush (brass bush)	Page 37
⊙ 12.	<b>Disassembly / assembly of the brake cylinders</b> .....	<b>Page 42</b>
	12.1 Spring brake cylinder disassembly	Page 42
	12.2 Spring brake cylinder assembly	Page 43
⊙ 13.	<b>Troubleshooting</b> .....	<b>Page 46</b>

# Product identification 1

## BPW type plate - brake

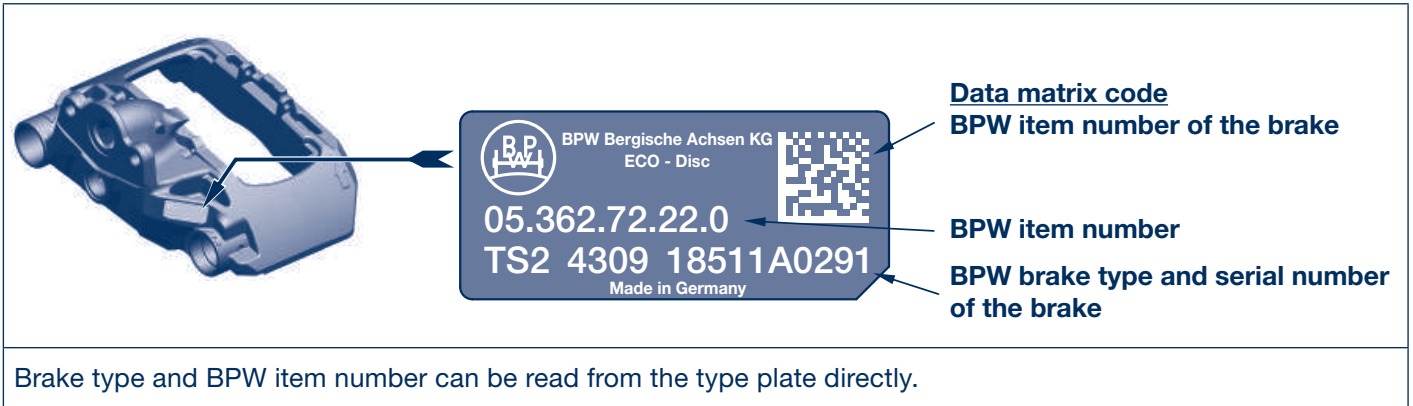

## 2 Safety regulations, safety information

### 2.1 Safety regulations

- All work must be performed by trained mechanics at qualified service centres and authorised specialist companies who have access to all relevant tools and have acquired the know-how required for this work. Anyone who performs maintenance and repair work must be trained in automotive mechanics and already have experience in repairing drawbar trailers, semi-trailers and engine-driven vehicles. Anyone who performs brake work must be trained in brake systems.
  - Comply with local safety regulations.
  - The relevant operation and service regulations as well as safety regulations of the vehicle manufacturer and of the manufacturers of other vehicle parts must be adhered to.
  - The grinding of brake linings creates very fine-grained dust that can cause lung damage. A safety mask must therefore be worn to prevent brake dust from being inhaled.
  - Use prescribed dust washing devices or vacuum cleaners for cleaning; never use compressed air or other high-pressure devices.
  - Ensure adequate ventilation at the workplace.
  - The vehicle must be prevented from moving during repair work. Please observe the relevant safety regulations for repair work on commercial vehicles, in particular the safety regulations for jacking up and securing the vehicle.
  - During repair work, make sure that the brake is not inadvertently operated. The brakes must be released.
  - Do not perform repair work unless wearing protective clothing (gloves, safety boots, safety goggles, etc.) and using the recommended tools.
  - Work on the brake outside of the vehicle must be carried out with the brake clamped in a device, such as a vice.
  - Only use recommended tools.
  - When removing the brake caliper, only touch it on the sides with your hands to avoid crushing your fingers.
  - A second mechanic must provide assistance when working with heavy components (brake discs or brake disassembly/assembly).
  - All air lines and components must be depressurised before opening.
  - Following each repair, perform a function check or a test drive in order to make sure that the brakes are functioning correctly. The braking effect of new discs and linings is only optimum after a few braking actions. Avoid hard braking.
  - All exchanged components must be reused or disposed of in accordance with the applicable environmental regulations, laws and directives.
  - The brake caliper with the clamping unit must not be opened. The fixing screws of the cover plate as well as the bolt in the area of the brake lever must not be unscrewed or released.
  - Carry out a visual inspection of the remaining brake lining thickness (see page 14) and the condition of the brake disc (see page 15) at regular intervals depending on how frequently and for what applications the vehicle is used.
  - Tighten screws and nuts with the prescribed tightening torque.
  - If the disc brake is positioned in the wheel brace, only use wheels with valves outside the wheel brace.
  - The user must ensure that collisions between brake caliper and adjacent components do not occur during operation.
-

## 2.2 Safety information

This workshop manual contains different types of safety instructions, each of which is marked by an icon and a signal word. The signal word describes the severity of the potential danger.



Danger!  
Warning!  
Caution!

**Immediate** potential danger of serious or fatal injury (severe injury or death).

**Possible** potential danger of serious or fatal injury (severe injury or death).

**Possible** dangerous situation (slight injury or damage to property).



Repair note!

Warning of damage to property or consequential damage if this information is not observed.



Note!

Application hints and especially useful information.



Mandatory!

Do not use an impact wrench. Doing so would cause considerable damage!

It is essential that maintenance is carried out in accordance with the prescribed intervals in order to maintain the safe operation and road safety of the vehicle.

Rectification of any defects which are discovered or replacement of worn brake disc parts should be carried out by a BPW Service Centre or BPW Direct Service Partner unless the vehicle owner has the required specialist personnel, the required technical facilities and workshop manuals or possesses an official certificate to perform interim inspections or special brake inspections.

**When installing spare parts, it is strongly recommended to only use original BPW components.**

**The warranty becomes null and void if spare parts other than original BPW parts are used in the context of warranty work.**

### 3 Exploded view / Name

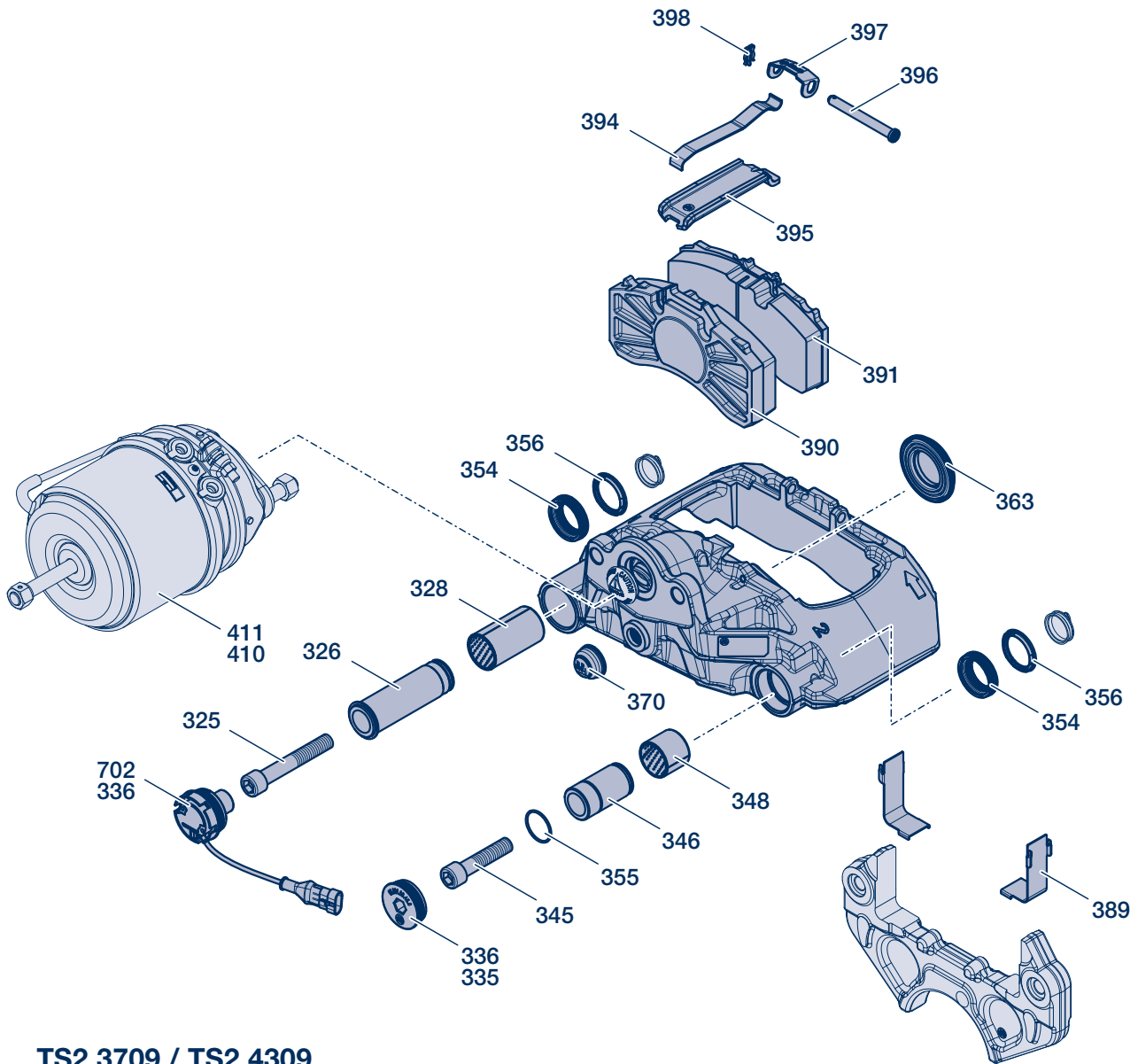

**TS2 3709 / TS2 4309**

Item	Name	Item	Name
325	Cylinder head screw	389	Wearing plate
326	Guide pin, long (fixed bearing)	390	Brake lining active (lining back plate with friction lining)
328	Guide bush (fixed bearing)	391	Brake lining passive (lining back plate with friction lining)
335	Sealing cap	394	Clamping spring
336	O-ring	395	Brake pad retaining clip
345	Cylinder head screw	396	Bolt
346	Guide pin, short (floating bearing)	397	Holding clamp
348	Guide bush (floating bearing)	398	Split pin
354	Bellow	410	Brake cylinder
355	O-ring	411	Brake cylinder
356	Ring	702	Brake pad wear sensing (see also installation and operating instructions for BrakePadMonitor)
363	Bellow with pressure plate		
370	Cap		

# Tightening torques **4**

Item	Description	Thread / spanner size	Tightening torques
325, 345	Brake caliper fixing screws ⚠ Use new fixing screws for every assembly! ⚠	M 16 x 1.5 / AF 14	M = <b>260 Nm</b> (250 - 270 Nm) or otherwise M = 150 Nm +180° rotation angle
335	Sealing caps of the caliper guide ⚠ Use new sealing caps for every assembly! ⚠  For the version with BrakePadMonitor brake pad wear sensing, observe the separate installation and operating instructions!	AF 14	M = <b>15 Nm</b> (15 - 20 Nm)
410, 411	Attachment nuts for brake cylinder	M 16 x 1.5 / AF 24	M = <b>180 Nm</b> (180 - 210 Nm)
410, 411	Spring brake bolt on spring brake cylinder		M = <b>40 Nm</b> (30 - 50 Nm)





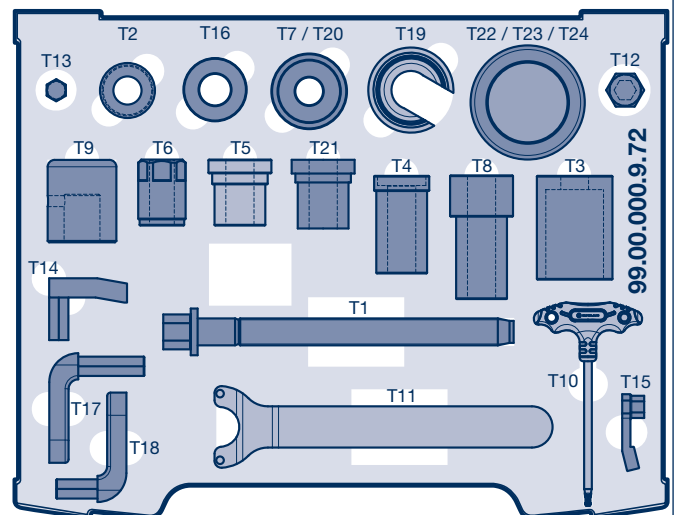

## 5 Special tools

### ↓ Brake tools ↓

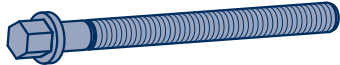
ECO Disc tool case for TS2 / TSB

BPW item number:  
**99.00.000.9.72**

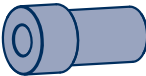

Consec. no.	Description	Illustration of tool	BPW item number:
T1	Threaded spindle		<b>02.0130.39.10</b>
T2	Ball bearing		<b>02.0130.40.10</b>
T3	Sleeve		<b>02.1410.26.00</b>
T4	Extractor tool for floating and fixed bearings		<b>02.0130.41.10</b>
T6	Nut		<b>02.5270.37.00</b>
T7 / T20	Retractable plate		<b>02.1421.25.00</b>
T8	Pressing tool for fixed bearing		<b>02.0130.43.10</b>
T21	Pressing tool for floating bearing		<b>02.0130.72.20</b>

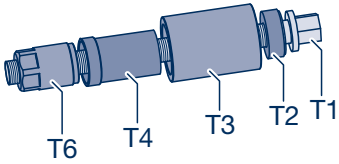
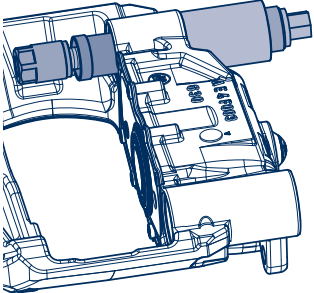
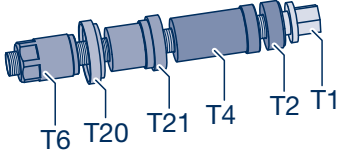
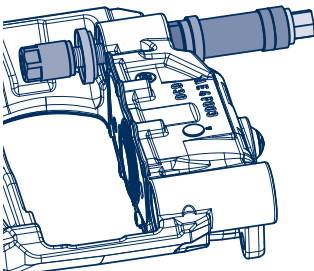
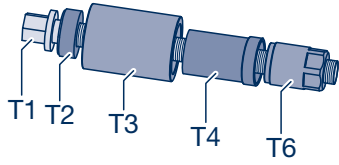
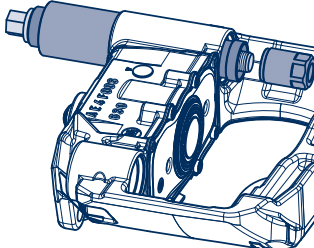
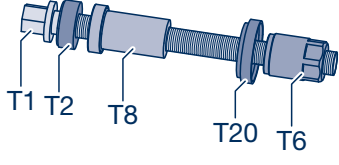
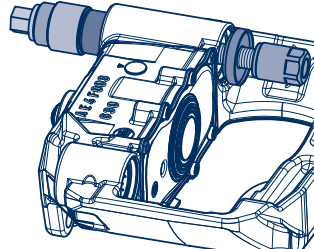

Consec. no.	Description	Illustration of tool	Tool in operation
	<p>Extractor tool for floating bearing</p> <p>Tool component parts: T1, T2, T3, T4, T6</p>		
	<p>Pressing tool for floating bearing</p> <p>Tool component parts: T1, T2, T4, T6, T20, T21</p>		
	<p>Extractor tool for fixed bearing</p> <p>Tool component parts: T1, T2, T3, T4, T6</p>		
	<p>Pressing tool for fixed bearing</p> <p>Tool component parts: T1, T2, T6, T8, T20</p>		

## 5 Special tools

ECO Disc tool case for TS2 / TSB

BPW item number:

**99.00.000.9.72**

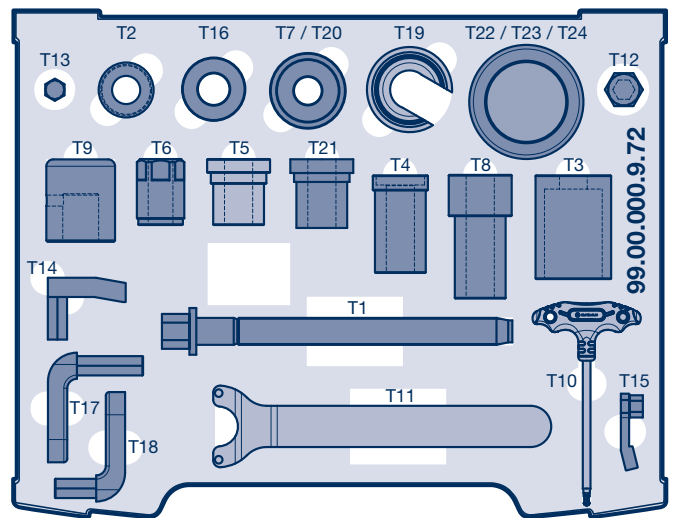

Consec. no.	Description	Illustration of tool	Tool in operation
T12	Adapter for moveable bearing bolt  BPW item number: <b>02.0130.46.10</b> AF 14 / AF 24		
T13	Adapter for sealing cap  BPW item number: <b>02.0130.47.10</b> AF 14 / AF 12		
T14	Adapter for torque wrench (floating bearing)  BPW item number: <b>02.0130.48.10</b> AF 14		
T15	Adapter for torque wrench (sealing cap)  BPW item number: <b>02.0130.49.10</b> AF 14		

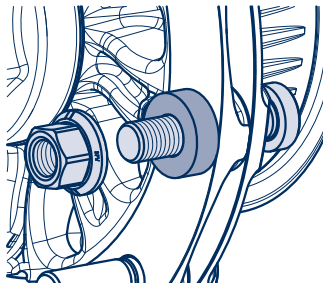
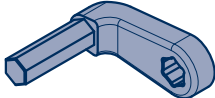
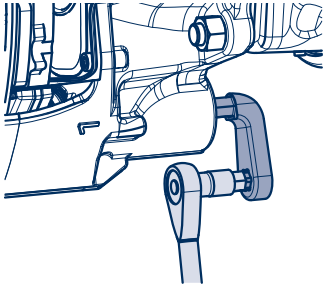
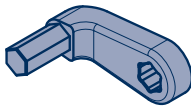
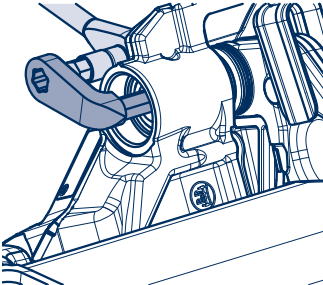
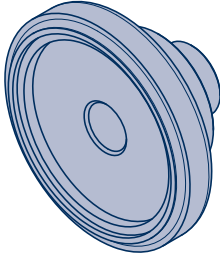
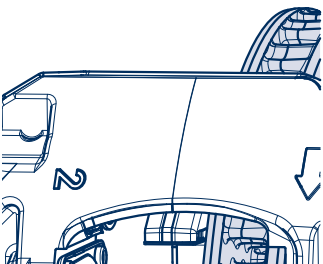
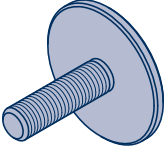
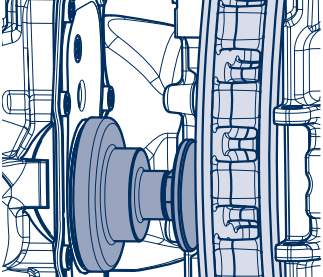
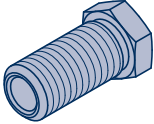
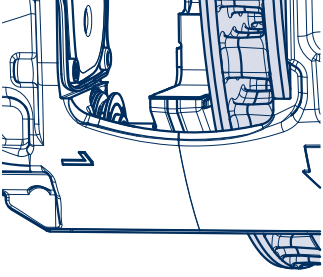
Consec. no.	Description	Illustration of tool	Tool in operation
T16	Ring for tightening the wheel studs  BPW item number: <b>02.5683.92.00</b>		
T17	Tool for fixed bearing bolt  BPW item number: <b>02.0130.64.10</b> AF 14 / AF 14		
T18	Tool for moveable bearing bolt  BPW item number: <b>02.0130.65.10</b> AF 14 / AF 14		
T22	Piston for bellow pressing tool  BPW item number: <b>02.0130.74.20</b> Ø 83 / M 20 x 2		
T23	Screw for bellow pressing tool  BPW item number: <b>02.0130.73.20</b> M 14 x 2		
T24	Spacer for bellow pressing tool  BPW item number: <b>02.4319.42.00</b> AF 24 / M 20 x 2 / M 14 x 2		

## 5 Special tools

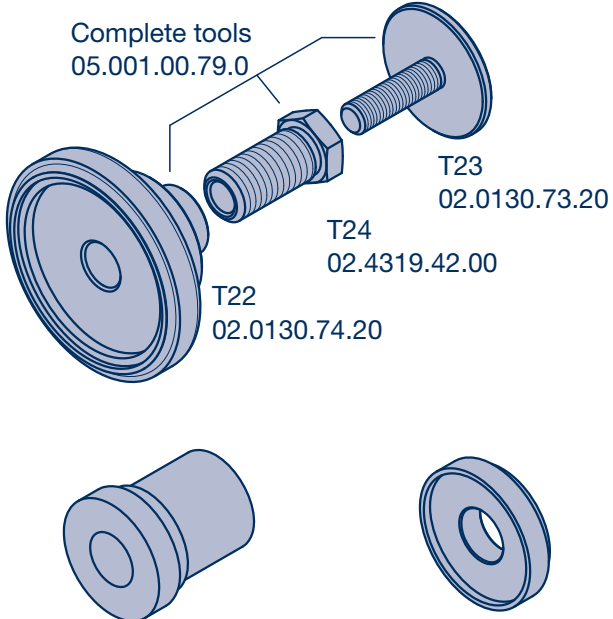
Description	Illustration of tool
<p>TS2 supplemental set for TSB tool case</p> <p>BPW item number:</p> <p><b>09.801.08.82.0</b></p>	 <p>Complete tools 05.001.00.79.0</p> <p>T23 02.0130.73.20</p> <p>T24 02.4319.42.00</p> <p>T22 02.0130.74.20</p> <p>T21 02.0130.72.20</p> <p>T20 02.1421.25.00</p>

# Maintenance 6

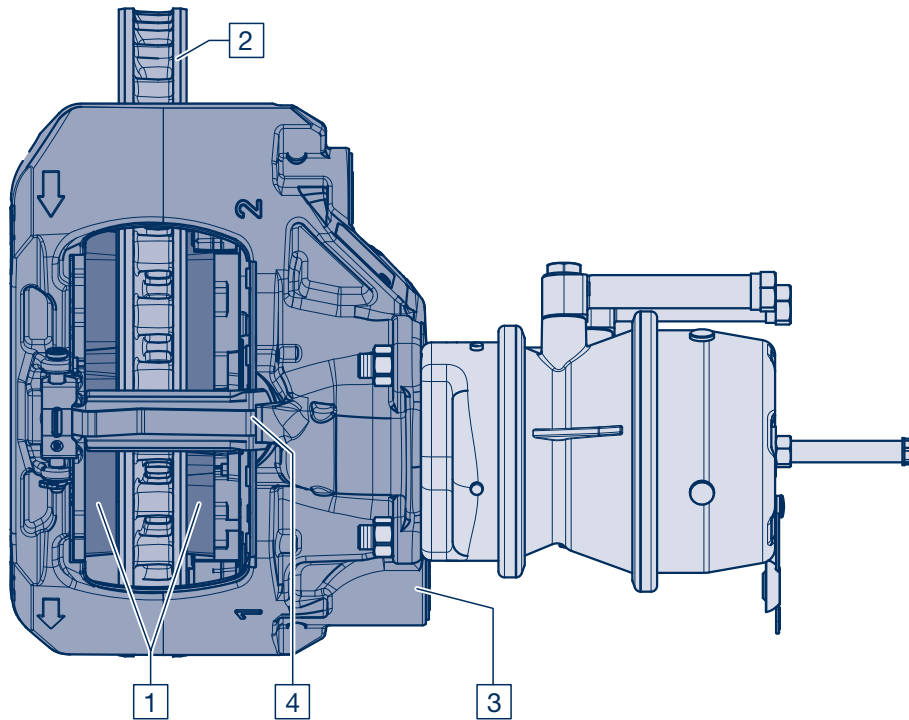

## Lubrication and maintenance

### Overview

For detailed description see pages 14 - 18

		every 12 weeks <sup>1)</sup>	every 26 weeks <sup>1)</sup>	annually and at every brake lining replacement
<b>Maintenance</b>				
1	Check brake lining thickness.	1		
-	Visual inspection, check all components for damage, wear and corrosion.		-	
2	Check the brake disc for cracking and undersize.	2 <sup>2)</sup>	2	
3	Check brake caliper guide system.	3 <sup>2)</sup>	3	
4	Check bellow with pressure plate.		4 <sup>2)</sup>	4

<sup>1)</sup> For heavy-duty applications, check or lubricate more frequently (e.g. off-road, heavy-duty braking work).

<sup>2)</sup> For use outside Europe:

Note: Components that have been damaged due to an improper attachment are to be replaced if necessary after a review by a BPW Service Centre.

## 6 Maintenance

### 1 Check brake lining thickness – quarterly –

Check the brake lining thickness regularly, e.g. when checking the tyre pressure, or after 3 months at the latest.



**Warning!**  
Worn brake linings reduce the braking performance and can ultimately cause the brakes to fail completely!

Inspection can be done as follows:

The brake lining thickness can be checked by the position of the brake caliper in relation to the welded-on brake anchor with the wheels mounted (approximate wear indicator).

Dimension x (distance between brake caliper and brake anchor):

12 mm => new condition

TS2 3709 / 4309

31 mm => max. permissible brake lining wear  
19 mm

35 mm => max. permissible wear for brake lining and brake disc

The brake linings must be removed to inspect them more closely; see chapter 8.

Scorched, glazed over, or oily brake linings must be replaced immediately.

The remaining brake lining thickness must **not** be less than 2 mm (check with a caliper gauge).

Small ruptures at the edges are allowed; large ruptures on the surface of the friction linings are not permitted.



**Repair note!**  
Only replace brake linings on the same axle at the same time!

### - Visual inspection – every six months –

Check all components for damage, wear and corrosion.

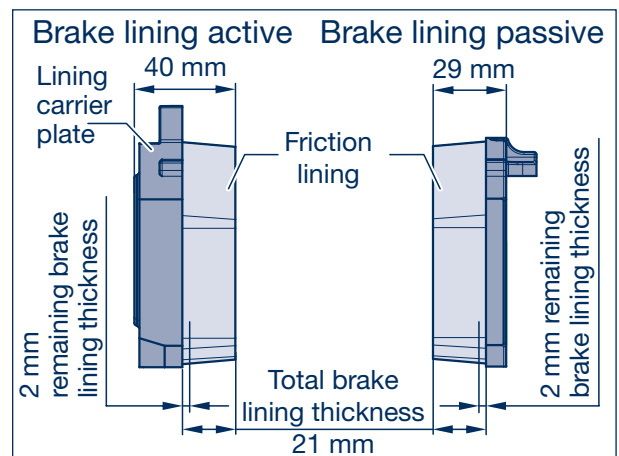
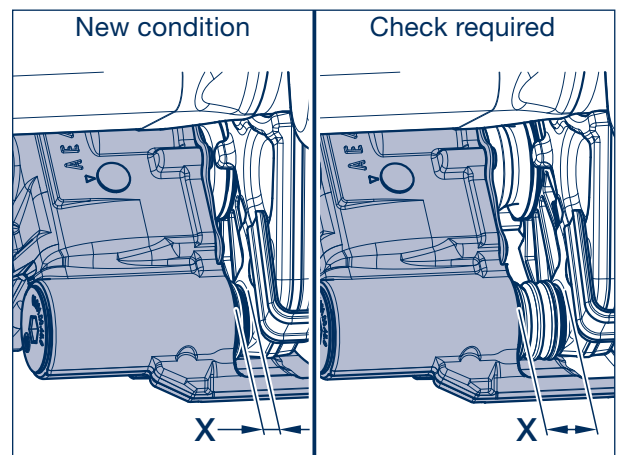
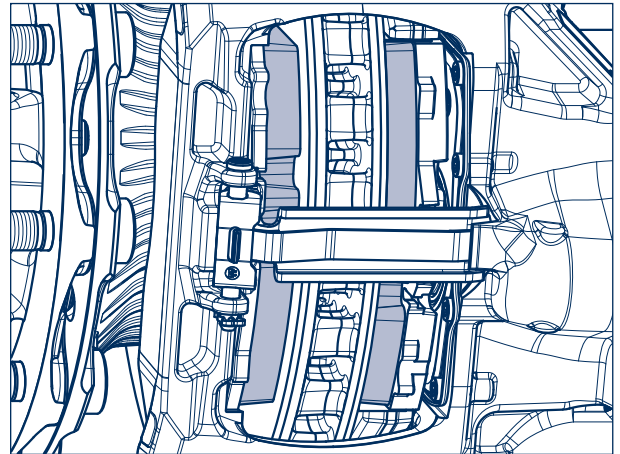

**2 Brake disc**

(Checking the condition of the brake disc)

- Every six months when used within Europe and every three months when used outside Europe -

Sections **A - D** (fig.) show the possible conditions of the disc surface:

- A** → Network-type cracks = permissible
- B** → Radial cracks up to max. 1.5 mm width and depth = permissible
- C** → Uneven disc surface less than 1.5 mm = permissible
- D** → Continuous cracks = **not permissible**

Technical data:

Disc thickness, new = 45 mm  
 Minimum permissible disc thickness = 37 mm  
 Maximum wear per side = 4 mm  
 (check with a caliper gauge where the brake linings make contact).

In the case of surface conditions as described for sections **A - C**, the brake disc can be used until the minimum permissible disc thickness has been reached.

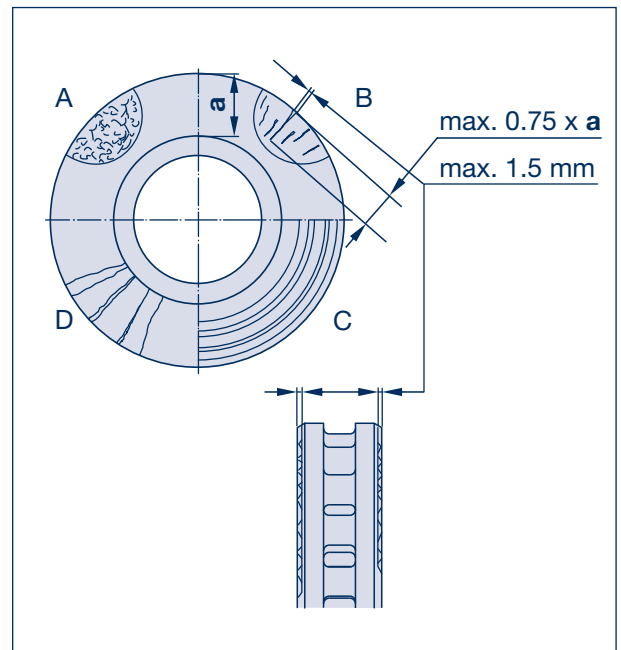
**Repair note!**

To prevent the brake disc from being damaged, the brake linings must be replaced at the latest when the brake lining thickness has been measured at 2 mm over the carrier plate.

**Repair note!**

Brake discs should always be replaced on the same axle at the same time. The brake linings should also be replaced when new brake discs are installed.

**Warning!**

If these instructions are not followed, the brake disc can be damaged and the braking effect can decrease or completely fail when the brake linings are worn down.

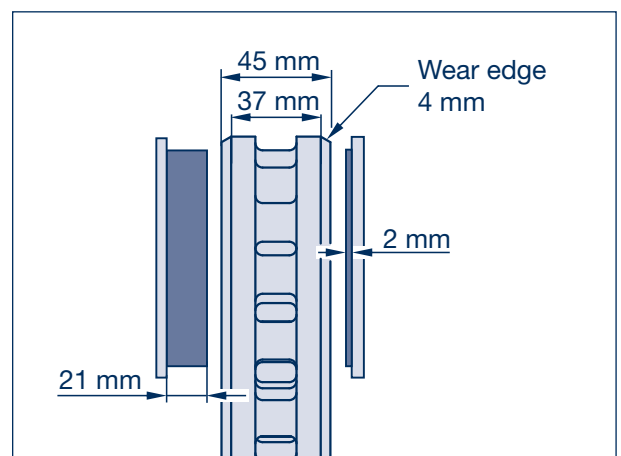



## 6 Maintenance

- 3 Check the brake caliper guide system**  
(check clearance and adjustment)
- Every six months when used within Europe,  
every three months when used outside Europe –  
(e.g. within the scope of the statutory checks)

**Secure the vehicle from rolling away.  
Release the service and parking brake.**

The brake cylinder and attachment parts for the brake linings can remain fitted.

Forcefully pushing the sliding caliper in the direction of the axle must cause the caliper to move approximately 0.7 to 1.3 mm (clearance).

If the clearance is not within this tolerance, the brake caliper guide must be checked and the clearance readjusted.

Close examination of the clearance with  
the wheels mounted:

Use a dial gauge to determine the clearance.  
For this purpose, attach a dial gauge holder to the axle beam and position the probe on the outside of the fixed bearing sealing cap (335) or on the brake cylinder.

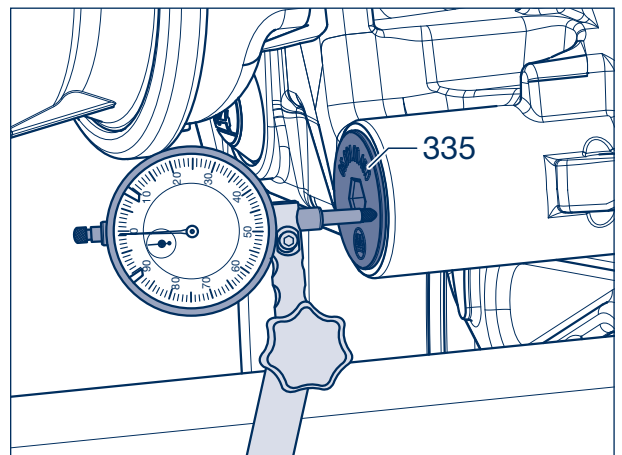
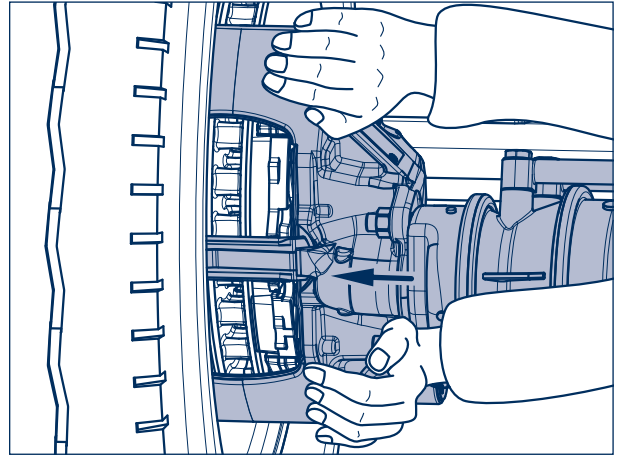

Close examination of the clearance with  
the wheels removed:

Use a feeler gauge to check the clearance.

Forcefully push the sliding caliper in the direction of the axle centre. Insert the feeler gauge between the bellow with pressure plate (363) and the brake lining back plate (390).

If the clearance is not within the tolerance, the adjustment and the brake caliper guide should be checked.

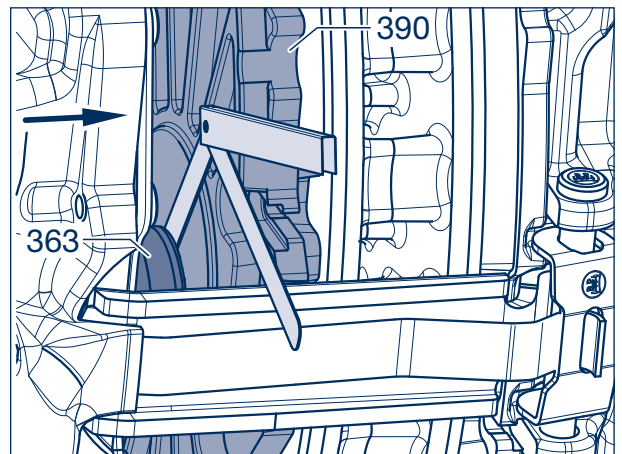



### Adjusting the clearance and checking the adjustment

1. Remove the sealing cap (370).
2. Turn the resetter with a spanner (AF 13) 90° **counterclockwise**.  
**Max. reset moment: 15 Nm**
3. Actuate the brake 5 to 10 times with approx. 2 bar.
4. When the sliding caliper is forcefully pushed in the direction of the axle, it must now be possible to move the sliding caliper by the clearance of 0.7 - 1.3 mm.

**If the clearance is correctly set, the adjustment is OK.**

5. Squeeze the seal cap (vented) and press it into the brake caliper (observe the installation instructions on page 26).

### Checking the brake caliper guide:

The brake caliper guide must be checked if the clearance has not been adjusted correctly.

Disassemble the brake linings, see chapter 8. It must be possible to move the brake caliper slightly from end stop to end stop.

The guide bushes (328, 348) are sealed by the bellows (354) and the sealing caps (335).

Inspect the bellows and sealing caps for cracks, damage, and proper seating and replace them if necessary.

**Sealing caps that have been removed must be replaced by new ones.**

Overhauling the brake caliper guide, see chapter 11.

### Check the brake caliper bearing play:

The bearing play of the brake caliper can be determined using a dial gauge. Attach the dial gauge holder to the axle beam and position the gauge on the brake caliper housing on the brake cylinder holder.

Press the brake caliper on the brake cylinder downwards vertically to its installation position and set the dial gauge to "zero".

Press the brake caliper upwards and determine the play of the bearing on the dial gauge.

If the play of the bearing of a brake caliper exceeds 1.0 mm, the brake caliper bearing must be replaced.

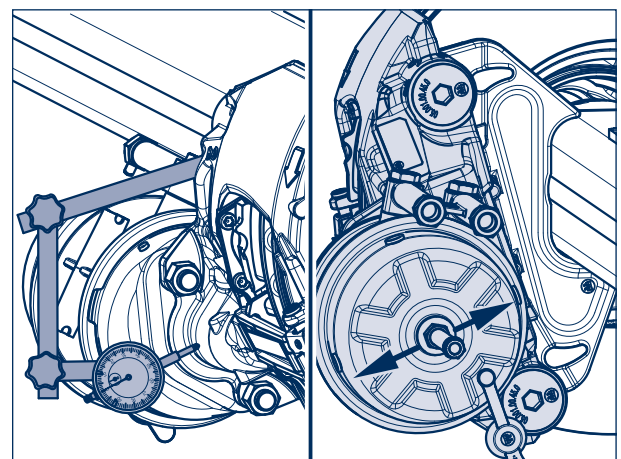
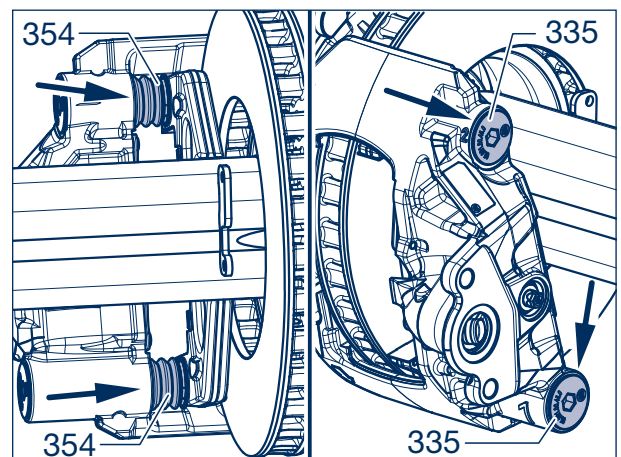
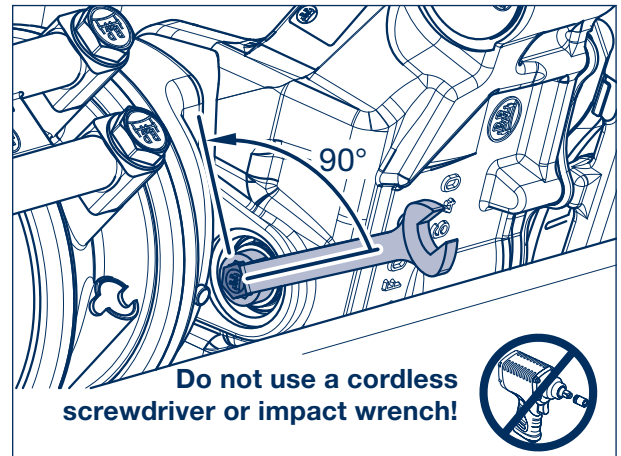

## 6 Maintenance

- 4 **Check the bellow with pressure plate**  
 – at every brake lining replacement and at the latest annually,  
 every six months when used outside Europe –

Secure the vehicle from rolling away.  
 Release the service and parking brake.

Disassembling brake linings (390, 391), see chapter 8.

The service brake and spring brake must be in the released condition.

Pull the pressure plate with heat protection cover and bellow (363) out of the dust cover slightly.  
 Check the complete unit for proper seating and damage; replace it if necessary.

Check the dust cover (arrow) for deformation. If a deformation is detected, the brake caliper must be replaced!

If a thermal overloading of the brake has been detected, the bellow with pressure plate (363) must be replaced.

Before the new bellow with pressure plate is installed, the adjusting unit must be checked for corrosion and ease of movement .

After the check or replacement, the bellow must be folded correctly and returned to its initial position. The pressure plate rests against the threaded sleeve (see figure 1 on page 20).

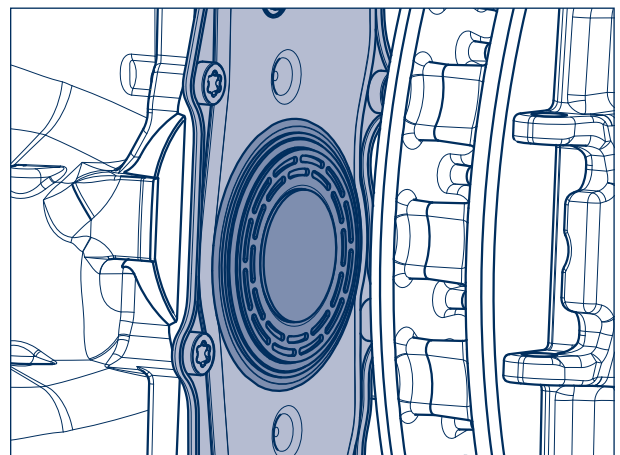
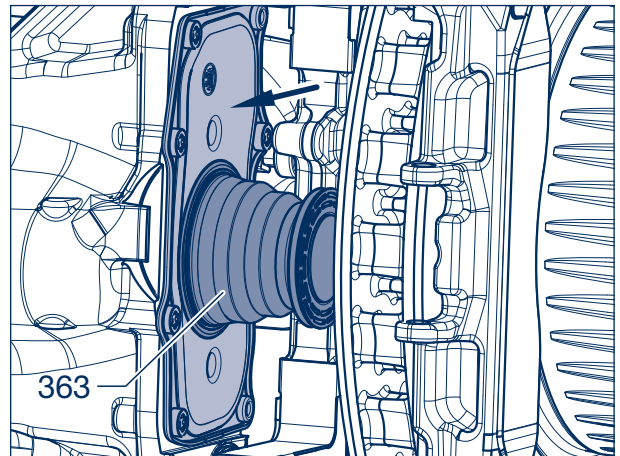

**Repair note!**

**The bellow with pressure plate must be replaced each time that the brake disc is changed.**

Changing the bellow with pressure plate, see chapter 10.



**Repair note!**

**The penetration of dirt and moisture causes corrosion and affects the operation of the clamping mechanism and adjustment.**



# 7 Structure and function

## FUNCTION

### PRINCIPLE: SLIDING CALIPER BRAKE

#### 7.1 Applying the brake

During braking, the push rod of the spring brake or diaphragm cylinder presses onto the brake lever (1).

The offset position of the brake lever amplifies the force created by the brake cylinder and allows it to be transferred to the traverse (3) via a needle bearing (2).

This clamping force acts on the inner brake lining (5a) via the traverse and the threaded sleeve (4).

Once the clearance between the inner brake lining and the brake disc (6) has been overcome, the reaction force is transferred to the outer brake lining (5b) via the brake caliper.

The braking moment for the wheel results from the contact pressure of the brake linings on the brake disc.

The radial stabilizer force created by the responding brake lining at this time is transferred directly to the axle via the brake caliper.

#### 7.2 Releasing the brake

When the braking pressure decreases, the pressure springs (7) move the brake actuating unit back to its initial position.

#### 7.3 Adjustment

The brake is fitted with an automatic non-wearing adjusting device to maintain a constant clearance between the brake linings and the brake disc.

Each brake application also simultaneously actuates the adjustment hub (9), which is coupled with the brake actuating unit via a shift sleeve (10), via an adjustment pin (8) in the brake lever. A reset shaft (11) with toothed washer (12) connected to the shift sleeve defines the clearance of the disc brake via the tooth pitch.

When the clearance increases due to brake lining and brake disc wear, the threaded sleeve (4) is turned by the degree of wear through adjustment via a wrap spring (13).

When the clearance is correctly set, the wrap spring slides through without turning the threaded sleeve.

The overall clearance (total clearance on both sides of the brake disc) measures 0.7 to 1.3 mm.

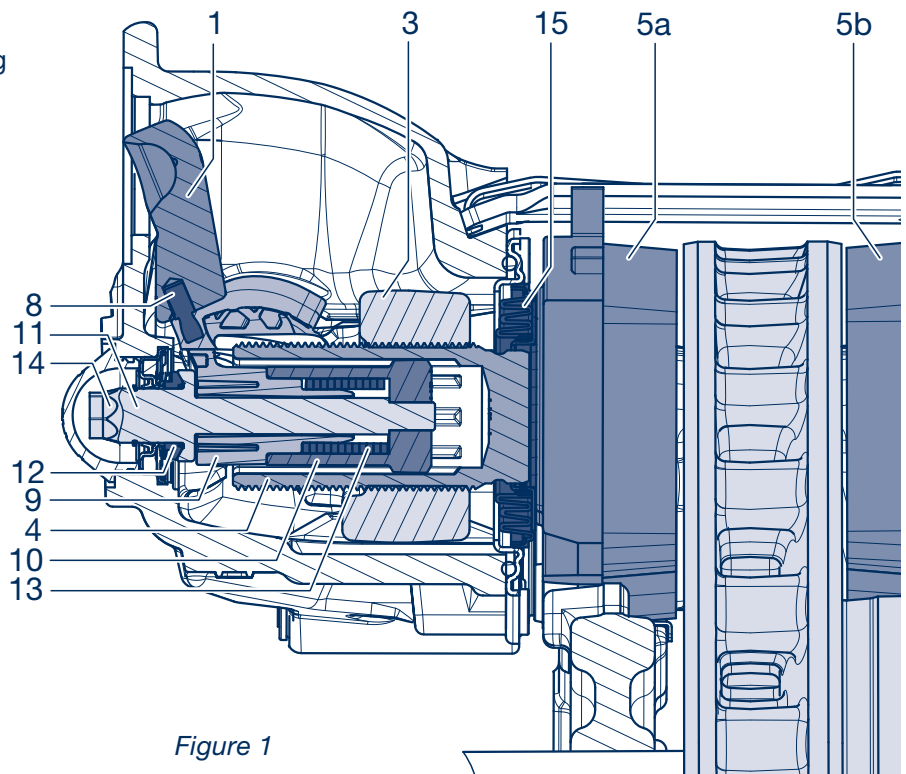

Figure 1

## 7.4 Reset mechanism

The disc brake features a reset mechanism at the back for replacing the brake linings and brake disc.

To reset the threaded sleeve to its initial position, the reset shaft equipped with a hexagon connection (14) is moved back using a slight torque, or the clearance of the brake is preset.

## 7.5 Brake cylinder

When compressed air is applied to the brake cylinder, an air cushion forms behind the diaphragm.

This forces the push rod out of the cylinder via the diaphragm plate.

The brakes may only be fitted with brake cylinders which - apart from the sealing of the flange surface - are fitted with a so-called "inner sealing".

This means that the push rod acting on the lever (1) must be hermetically sealed from the secondary chamber of the brake cylinder, as otherwise the clamping mechanism will be completely open to its surroundings.

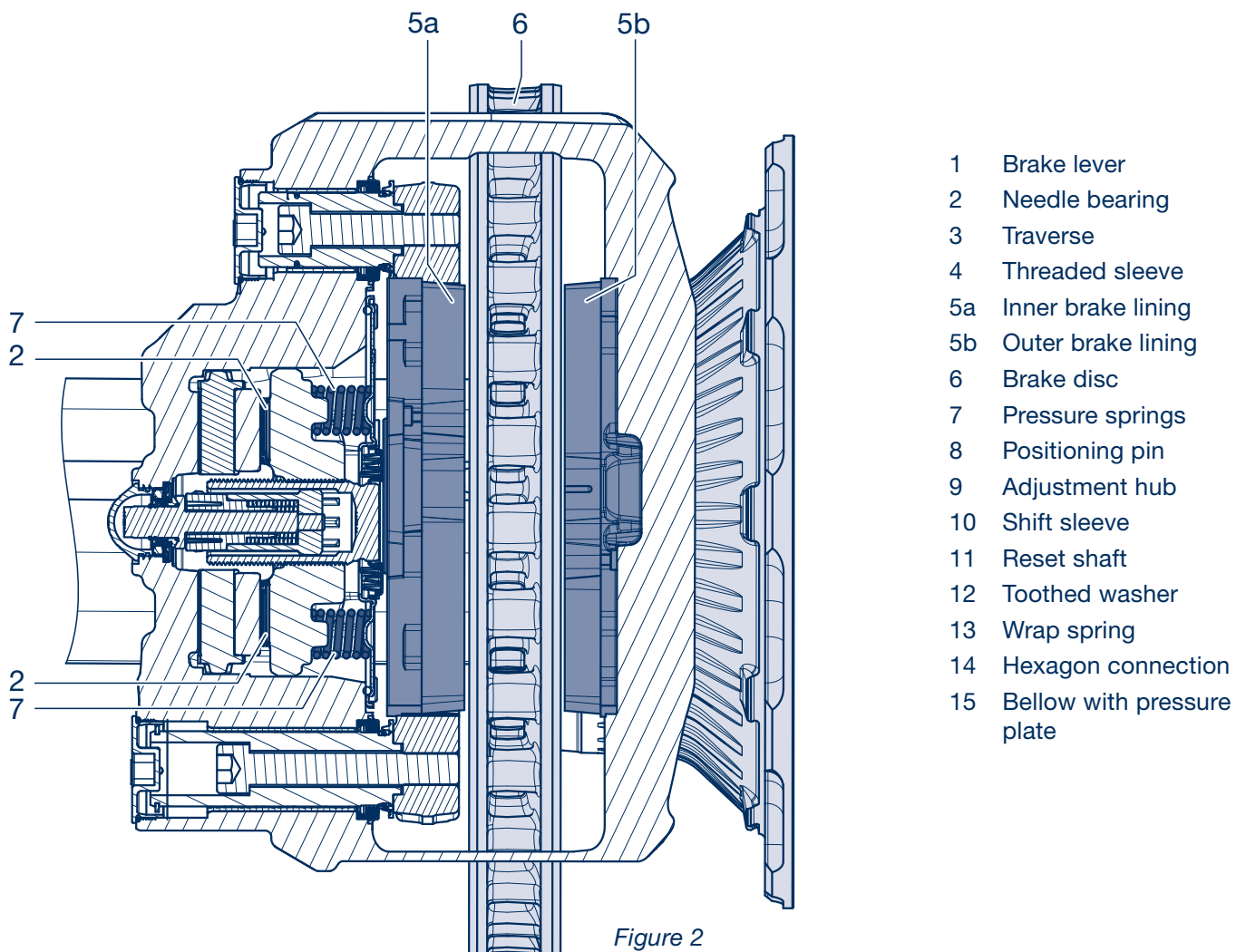

Figure 2



## 8 Changing the brake linings



### Repair note!

Only replace brake linings on the same axle at the same time!  
Before the brake linings are installed, the brake must be reset completely.

- [1] Prevent the vehicle from rolling away.
- [2] Release the service and parking brake and dismount the wheels as needed.
- [3] Remove the sealing cap (370) of the resetter with a screwdriver.

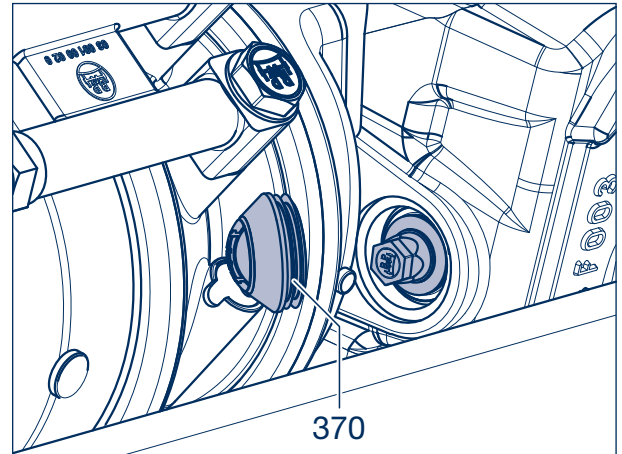

Figure 1

### 8.1 Resetting the threaded sleeve

- [4] Using a spanner (AF 13), turn the resetter counter-clockwise until the pressure plate with bellow has been completely reset. (If nec., manually turn back the pressure plate with bellow to the compressed condition.)

**Max. reset moment: 15 Nm**



### Repair note!

If the max. reset torque is exceeded, the adjustment can be irreparably damaged.



### Attention!

Do not use a cordless screwdriver or impact wrench. Using these tools would cause considerable damage!

- [5] Pull the spring split pin (398) out of the bolt (396) with a spring plier.

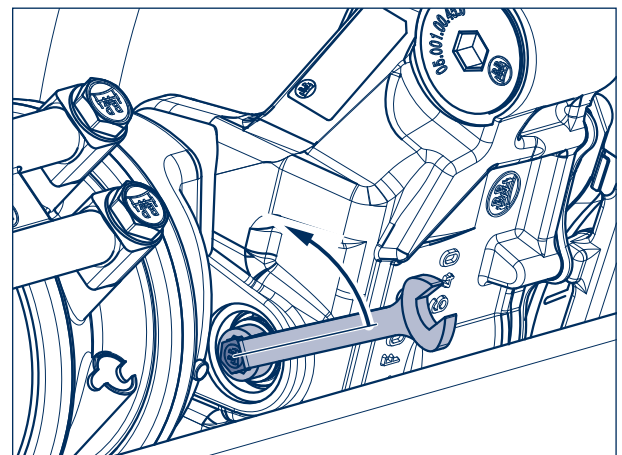

Figure 2

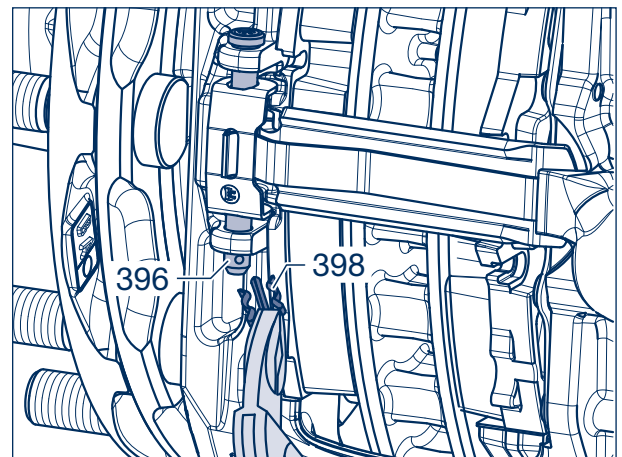

Figure 3

- [6] Depress the clamping spring (394) and remove the bolt (396) with holding clamp (397).

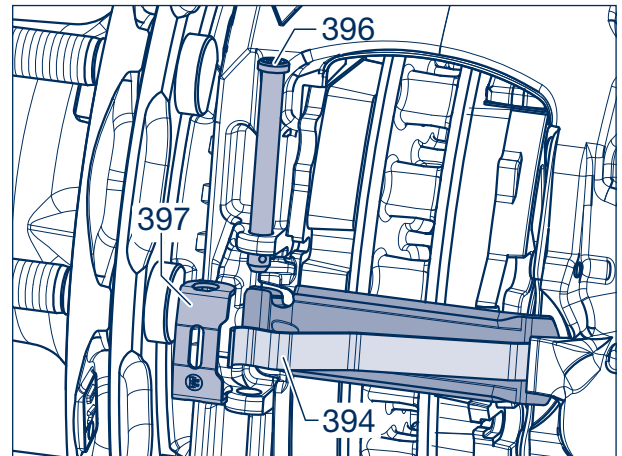

Figure 4



**Caution!**  
Apply counter pressure to the brake linings (390, 391) if necessary so that they do not fall out of the lining groove when the pad retainer is removed.

- [7] Remove the pad retainer (395) with clamping spring (394).

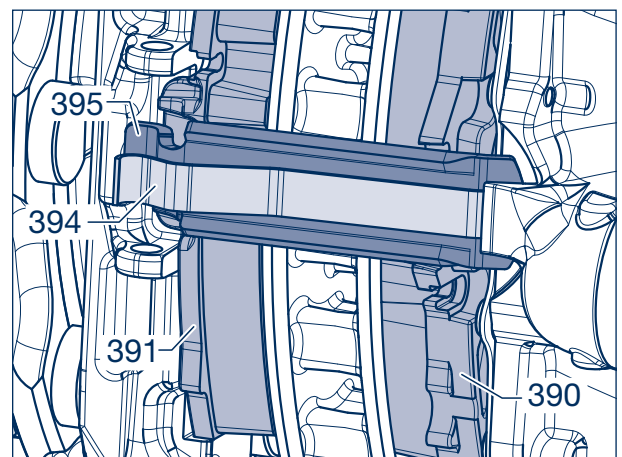

Figure 5

- [8] Remove the brake linings (390, 391).
- [9] After the brake linings have been removed, check the condition of the brake and the brake disc; see chapter 6, pages 16 to 18.
- [10] If no defects are found, you can continue with the replacement of the brake linings (390, 391).

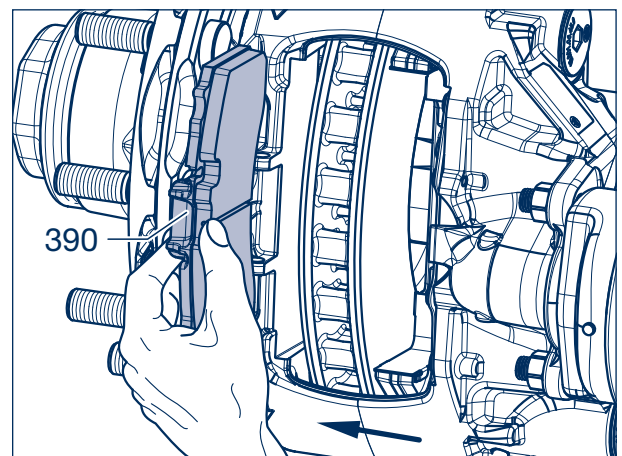

Figure 6

## 8 Changing the brake linings

- [11] Lever both wearing plates (389) off of the brake anchor. Clean the lining groove and the seats of the wearing plates on the brake anchor and remove corrosion.
- [12] Mount new wearing plates (389), greased on the rear side with BPW special longlife grease ECO-Li<sup>Plus</sup>, on the brake anchor. The lateral mounting brackets (arrow) fix the plates on the brake anchor.



### Repair note!

The brake disc must remain free of grease.



### Note:

Use only brake linings approved by BPW. Our warranty will become invalid if this instruction is not observed!



### Repair note!

If the brake disc is worn, the inner and outer radius (arrow) of the new linings must be chamfered (4 x 45°).



### Repair note!

Before the brake linings are installed, it must be ensured that the bellow with pressure plate (363) rests correctly folded against the dust cover (see figure on page 18).

- [13] Move the brake caliper towards the inside of the vehicle and insert the inner, active brake lining (390).



### Note:

The brake linings are supplied with different back plates.

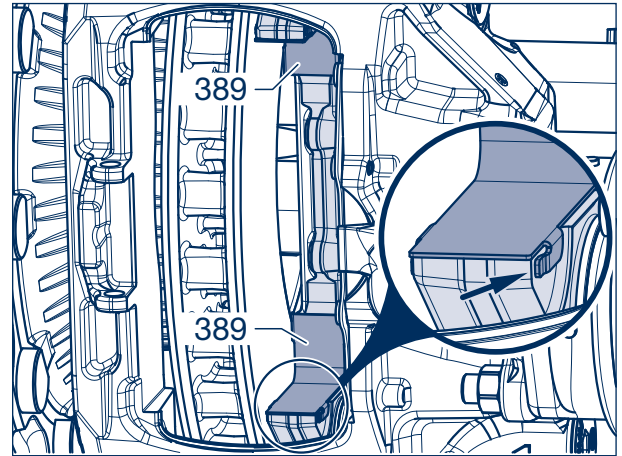

Figure 7

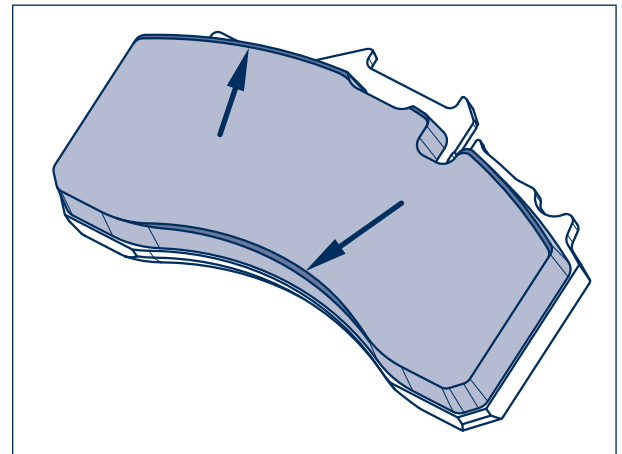

Figure 8

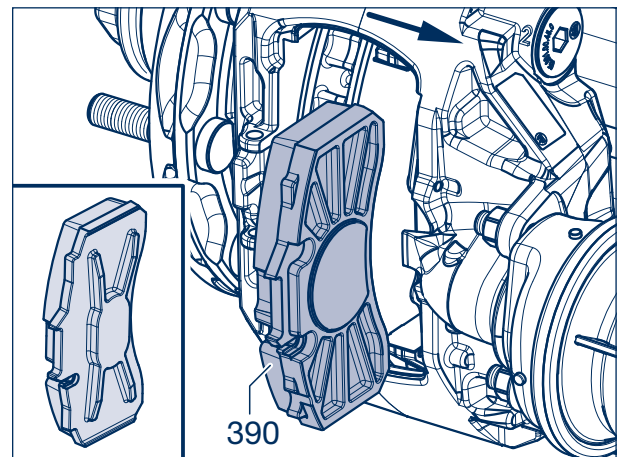

Figure 9



- [14] Slide the brake caliper towards the outside of the vehicle and insert the outer, passive brake lining (391).

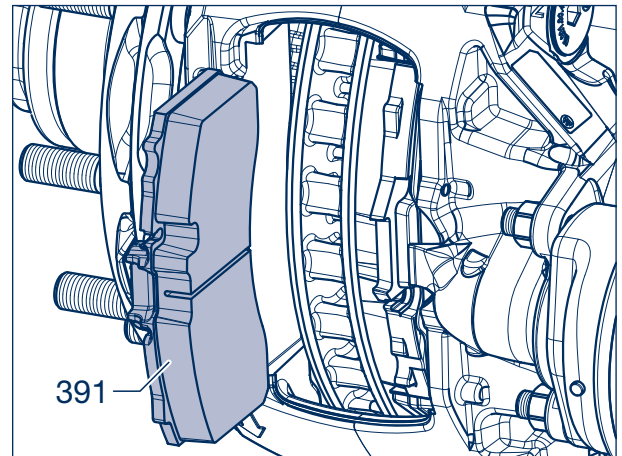

Figure 10

- [15] Guide the pad retainer (395) with clamping spring (394) into the saddle opening.
- [16] Place the holding clamp (397) onto the clamping spring and press it down together with the pad retainer until the bolt (396) can be inserted into the bore hole.

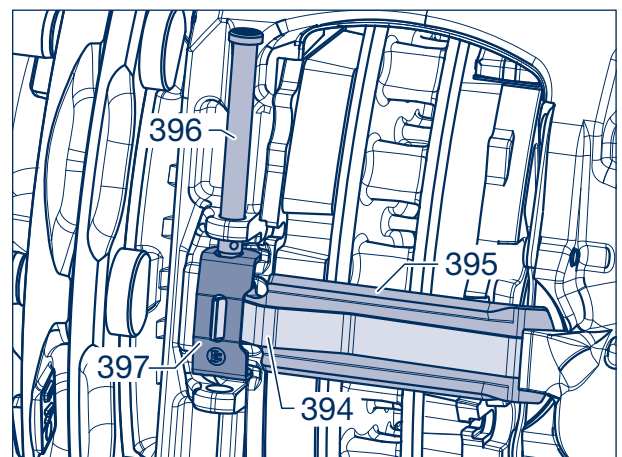

Figure 11

- [17] Insert the bolt (396) from above, and secure it with the spring split pin (398).
- [18] Following this, ensure that the wheel or hub can turn slightly when the brake is released.

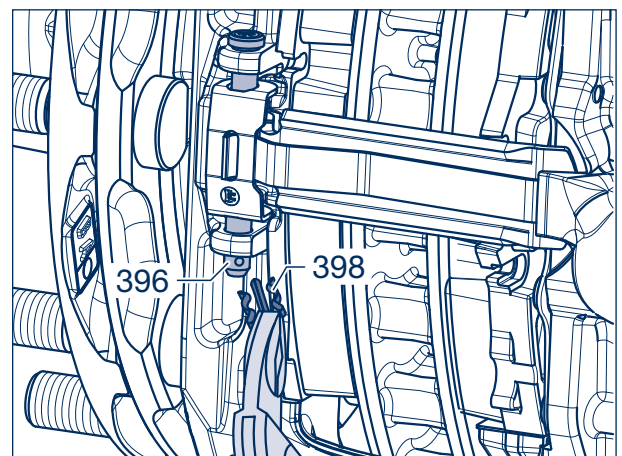

Figure 12

## 8 Changing the brake linings

### 8.2 Setting the clearance

- [19] Using a spanner (AF 13), turn the resetter counter-clockwise.
- [20] Advance the brake until the brake linings rest against the brake disc free of play.

**Max. torque: 15 Nm**



**Attention!**  
Do not use a cordless screwdriver or impact wrench. Using these tools would cause considerable damage!

- [21] Next, turn back the adjuster by 90°.

- [22] Slightly apply grease to both lamellae (arrow) of the sealing cap (370).
- [23] Squeeze the new sealing cap together (vented) and press it into the brake caliper.

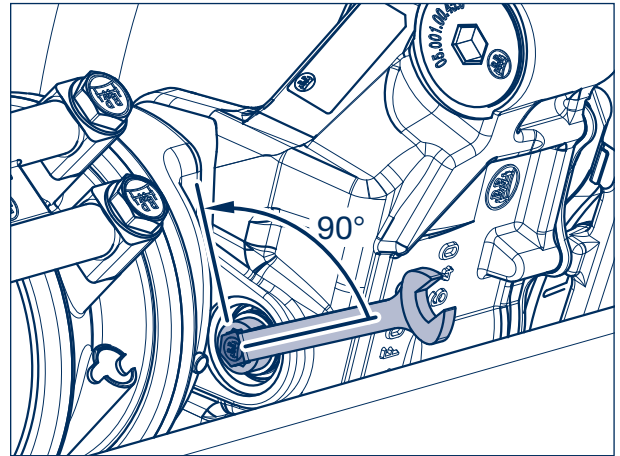

Figure 13

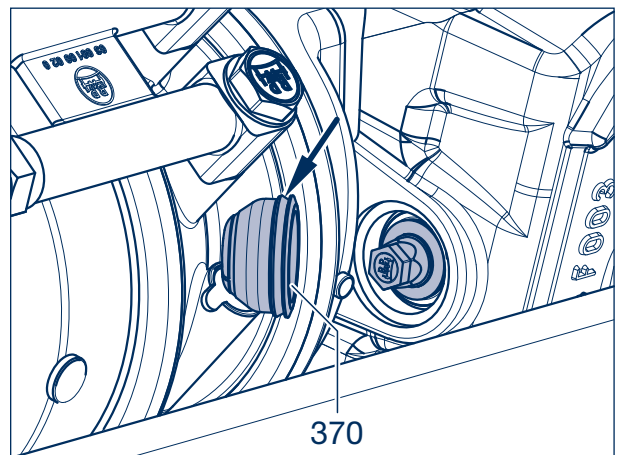

Figure 14



**Repair note!**  
After assembly, the sealing cap must be checked for correct seating. Both lamellae of the seal must lie inside of the holder (arrow) in the brake caliper.

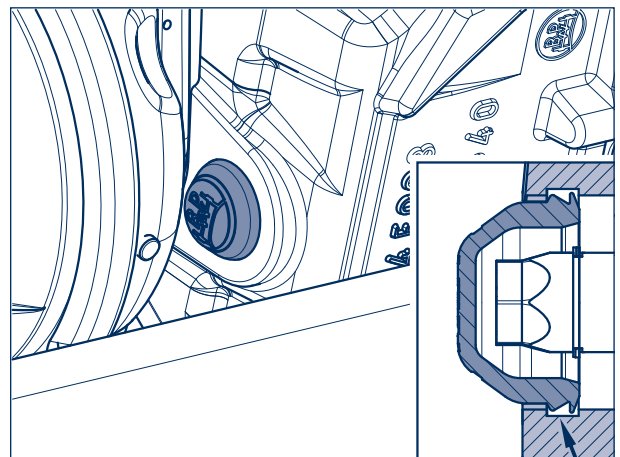

Figure 15

[24] Reattach the wheels.



**Repair note!**

If the disc brake is positioned in the wheel brace, only use wheels with valves outside the wheel brace.

The user must ensure that collisions between brake caliper and adjacent components do not occur during operation.

[25] Screw on the wheel nuts.

[26] Lower the axle and tighten the wheel nuts to the required tightening torque.



**Warning!**

The tightening torque of the wheel nuts must be checked after the first run under load conditions. If necessary, retighten them to the prescribed value.



**Warning!**

New discs and linings only have an optimal braking effect after a few braking operations.  
For this reason, run in new brake linings while avoiding lengthy and unnecessarily sharp brake operations.

## 9 Disassembly / assembly of the brake caliper

### 9.1 Removing the brake caliper

- [1] Remove the brake linings and, if present, remove the wear indicator cable (see chapter 8).
- [2] Remove the brake cylinder (see chapter 12).
- [3] Unscrew the sealing caps of the caliper guide (335) using the adapter (BPW no.: 02.0130.47.10 or 02.0130.49.10, AF 14).



**Warning!**  
Before loosening the cylinder head screws, secure the brake caliper against falling down.

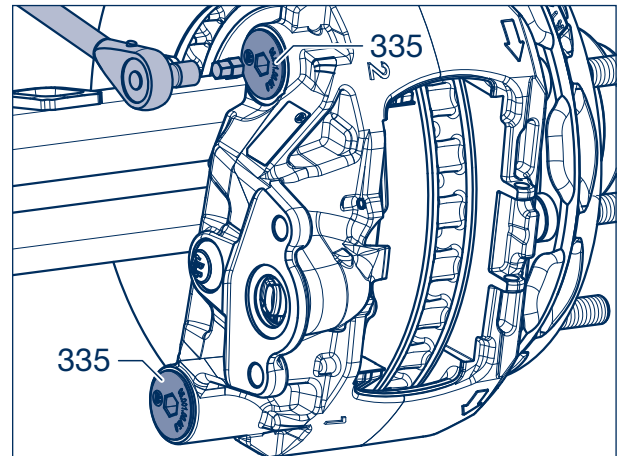

Figure 1

- [4] Unscrew the cylinder head screws (325, 345) with the adapter AF 14 mm, according to the version T12, T14, T17 or T18 (see page 10 and 11).

If there is enough clearance, a ratchet with a box spanner AF 14 can be used.



**Caution!**  
**DANGER OF CRUSHING!**  
Only hold the brake caliper on the outside. Never place fingers between the brake caliper and the brake anchor!  
Never attach a lifting device to the pad retainer, since the pad retainer can be damaged.

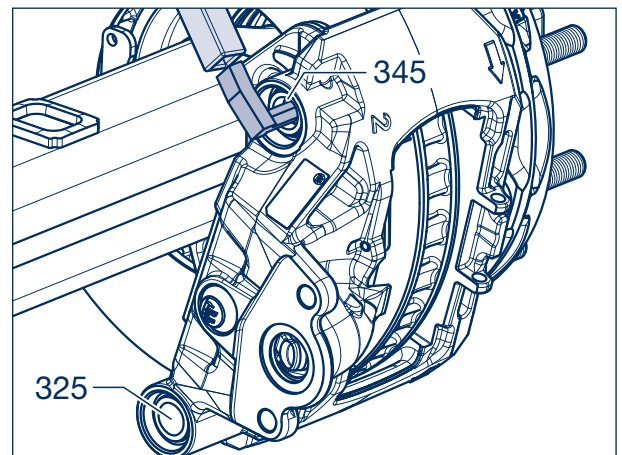

Figure 2



**Caution!**  
**DANGER OF INJURY!**  
The brake caliper must be secured against falling when it is taken down. Use a lifting device or second person for assistance.

- [5] Remove the brake caliper from the caliper anchor plate.



**Caution!**  
**DANGER OF ACCIDENT!**  
Do not open or dismantle a brake caliper.  
Only use replacement brake calipers.

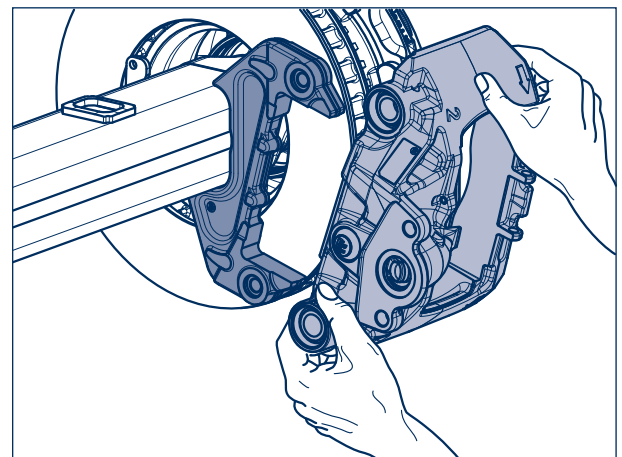

Figure 3

## 9.2 Installing a brake caliper

- ☞ Continue with step [12] if the brake caliper is to be reused.
  - [6] The sealing plugs (arrows) must be removed from the bellows (354) if replacement brake calipers are to be used.
- Note: The replacement brake calipers are pregreased with BPW ECO Disc grease.
- [7] Unscrew the sealing caps (335, see figure 1).

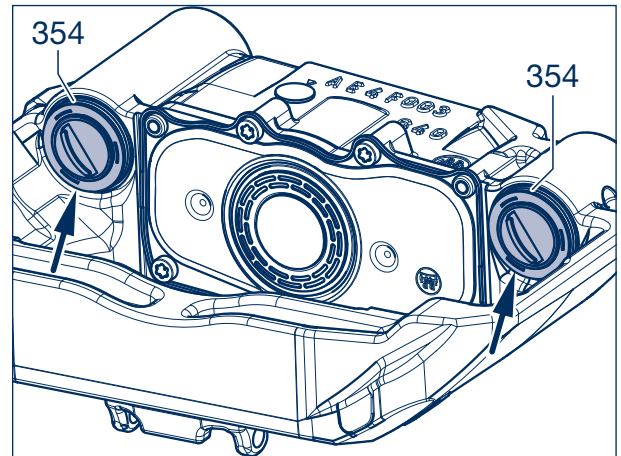

Figure 4

- [8] Coat the O-ring (355) with BPW ECO Disc Grease and insert it into the groove (arrow) of the floating guide pin.
- [9] Install the guide pins (326, 346).

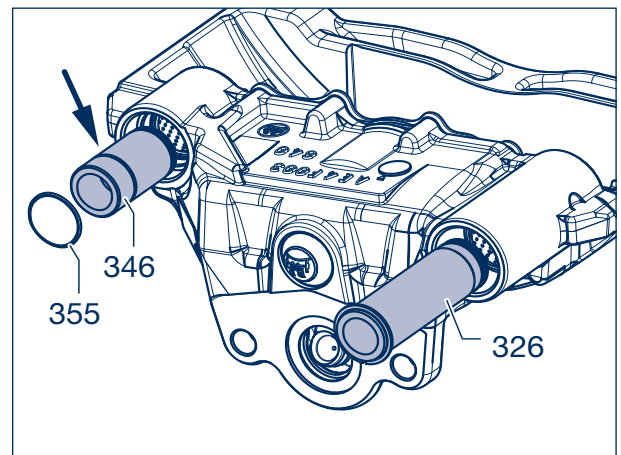

Figure 5

- [10] Insert the bellows (354) into the groove on the guide pins (326, 346, arrow).

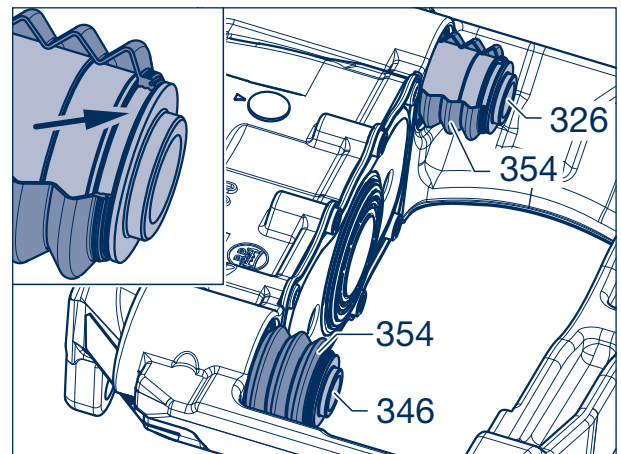

Figure 6



## 9 Disassembly / assembly of the brake caliper

- [11] Secure the bellow (354) in the groove of the guide pins (326, 346) by pushing on the ring (356).



**Note:**  
Check the guide pins (326, 346) for ease of movement before installing the brake.

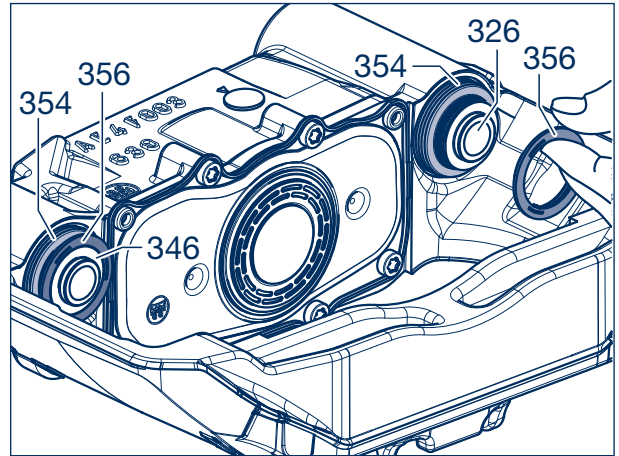

Figure 7

- [12] Place the brake caliper on the brake anchor. Observe the left-hand and right-hand version. The arrow on the brake caliper shows the direction of the wheel rotation.



**Repair note!**  
When placing the brake caliper, ensure that the bellows (354) have sufficient clearance in order to prevent damage.

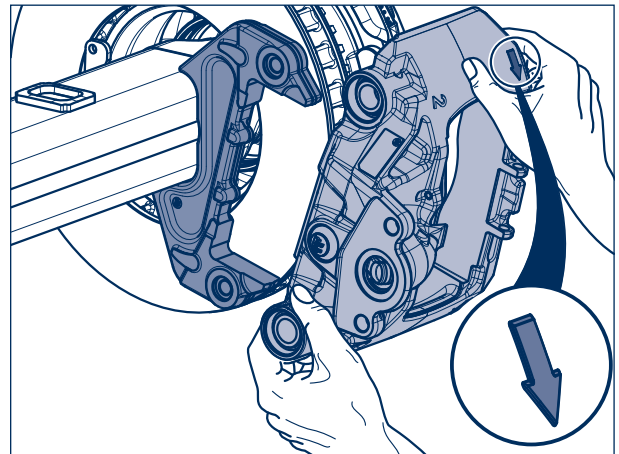

Figure 8



**Repair note!**  
Ensure that the bellow (354) and the ring (356) are seated properly on the guide pin when mounting the brake caliper.

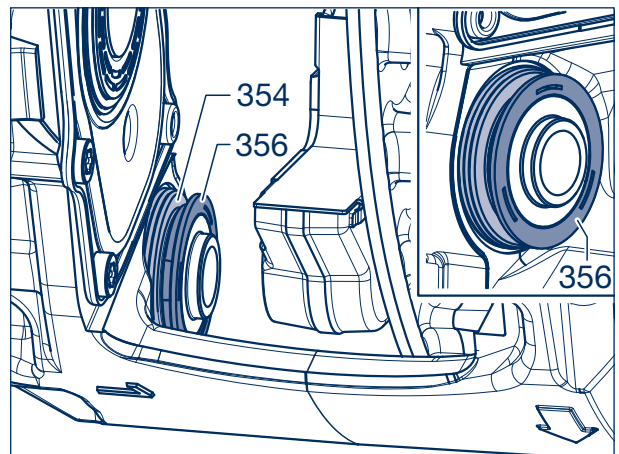

Figure 9



**Caution!**  
Cylinder head screws (325, 345) must not be re-used!

- [13] Apply BPW ECO Disc Grease to the new cylinder head screws (325, 345) on the thread and the screw seating.
- [14] Using an adapter AF 14, screw in according to version T12, T14, T17 or T18 (see page 10 and 11), and **do not tighten!**

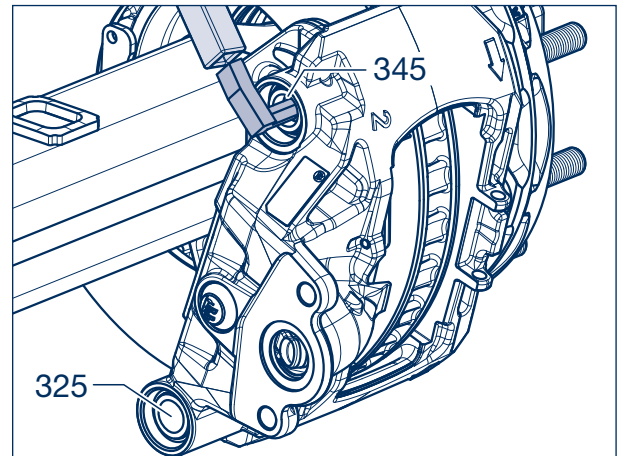

Figure 10



**Repair note!**  
For the brake function, it is essential to tighten the fixed bearing bolt (marking 1 on the brake caliper) to the required tightening torque first.

- [15] Tighten the cylinder head screw of the fixed bearing (325) with a tightening torque of:  
M = **260 Nm** (250 - 270 Nm)  
or otherwise with  
150 Nm + 180° rotation angle.

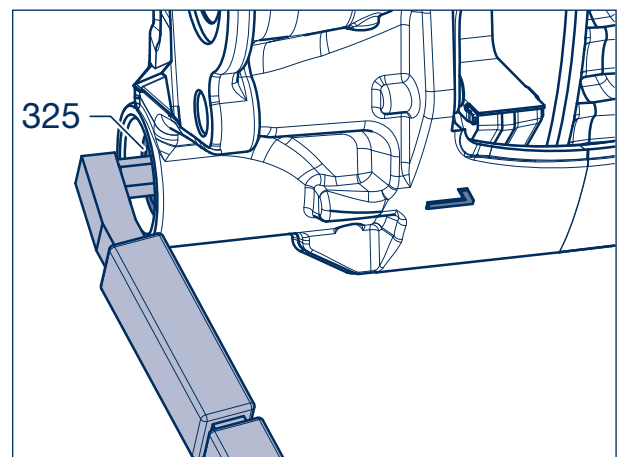

Figure 11

- [16] Tighten the cylinder head screw (345) of the floating bearing (marking 2 on the brake caliper) with a tightening torque of:  
M = **260 Nm** (250 - 270 Nm)  
or otherwise with  
150 Nm + 180° rotation angle.

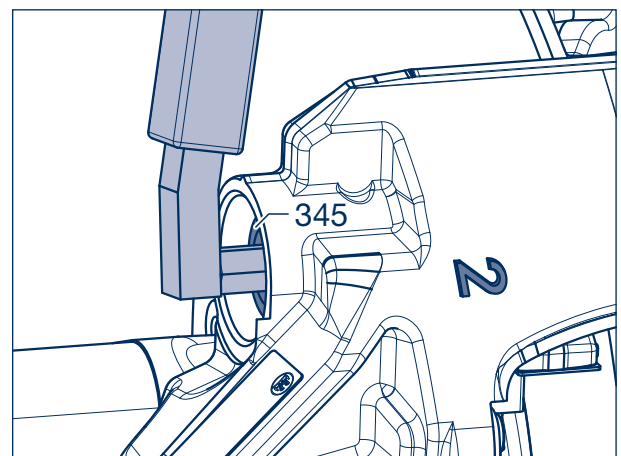



Figure 12

## 9 Disassembly / assembly of the brake caliper

[17] Push the new O-ring (336) onto a new sealing cap (335) until contact (arrow).

[18] Screw in new pre-assembled sealing caps for the caliper guide (335, 336) using the adapter (BPW no.: 02.0130.47.10 or 02.0130.49.10, AF 14). For this purpose, center the brake caliper in relation to the brake disc.  
Tightening torque:

**15 Nm** (15 - 20 Nm)

 For the version with BrakePadMonitor brake pad wear sensing, observe the separate installation and operating instructions!

[19] Check that the brake caliper can be moved easily.

[20] Install the brake linings; see chapter 8.

[21] Check the adjustment (not required with replacement brake calipers) and adjust the clearance; see also 3 page 17:

1. Remove the sealing cap (370).
2. Turn the resetter with a spanner (AF 13) 90° **counterclockwise**.

**Max. reset moment: 15 Nm**

3. Actuate the brake 5 to 10 times with approx. 2 bar.
4. When the sliding caliper is forcefully pushed in the direction of the axle, it must now be possible to move the sliding caliper by the clearance of 0.7 - 1.3 mm.  
If the clearance is correctly set, the adjustment is OK.
5. Squeeze the sealing cap together (vented) and press it into the brake caliper.



**Note!** When new brake calipers are used, the plug must be removed! Using a thin screwdriver, pierce the plug in the middle and lever the cap out of the brake caliper.

[22] Fit the spring brake cylinder (see chapter 12.2).

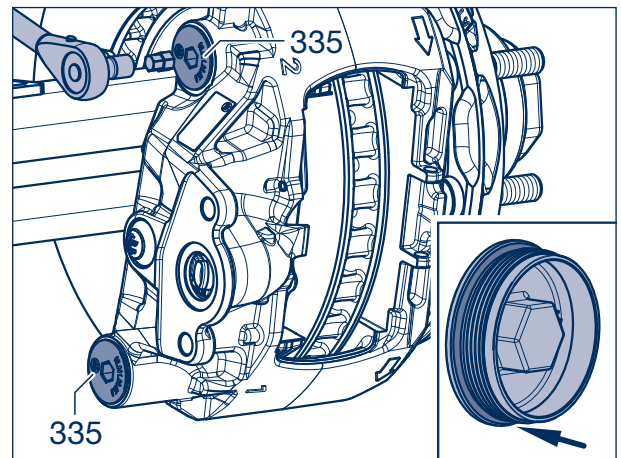

Figure 11

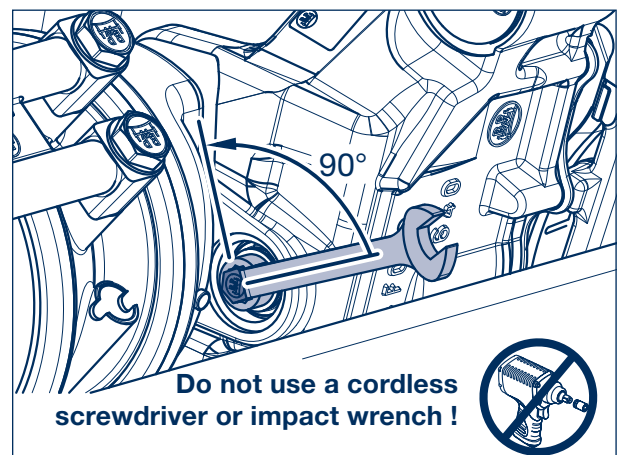

Figure 12

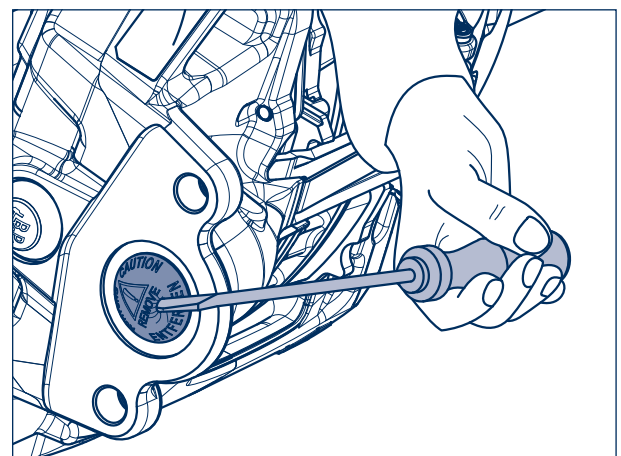

Figure 13



# Changing the bellow with pressure plate 10



### Note!

The inside of the brake caliper is exposed when the bellows are replaced. Do not allow dirt or moisture to enter this area. Clean the brake caliper beforehand if necessary.

- [1] Reset the bellow with pressure plate and remove the brake linings, see chapter 8.
- [2] Use a screwdriver to lift out and remove the bellow with pressure plate (363) from the dust cover. Do not deform the dust cover while doing so.



### Repair note!

The bellow with pressure plate (363) must be removed completely from the seat in the brake caliper. If the bellow has been torn off during disassembly, remove the remnants from the seat.



### Repair note!

The bellow must be free of damage and be dry and free of contamination on the inner side. Otherwise, the brake caliper must be replaced.

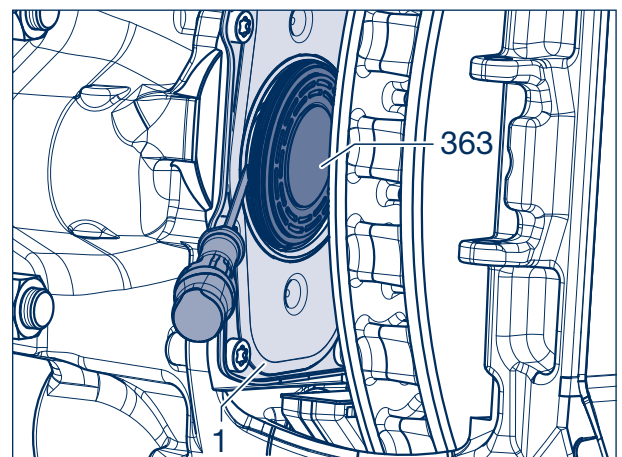

Figure 1

- [3] Screw in all components (T22, T23, and T24) of the assembly tool (BPW no. 05.001.00.79.0) up to the end stop.

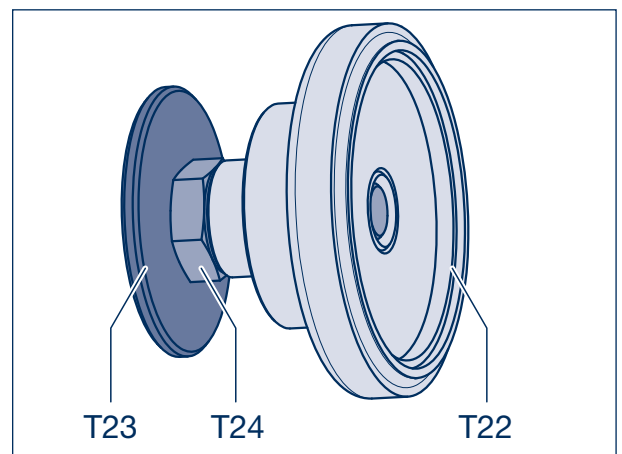

Figure 2

## 10 Changing the bellow with pressure plate

- [4] Insert a new bellow with pressure plate (363) into the piston (T22) of the assembly tool (rubber bellow points outwards).

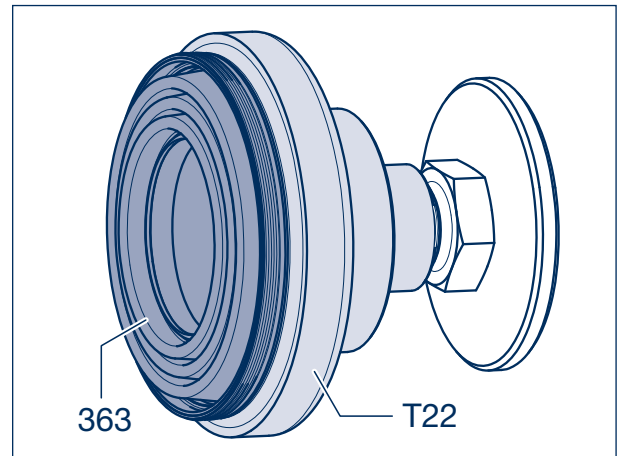

Figure 3

### Bellow assembly with an installed brake

- [5] Push the brake caliper as far as possible in the direction of the centre of the axle. Insert the assembly tool with bellow (363) between the brake disc (380) and the dust cover.
- [6] Center the bellow in the holder in the dust cover.
- [7] Unscrew the spacer (T24) of the assembly tool in a counterclockwise direction until it makes contact with the brake disc.

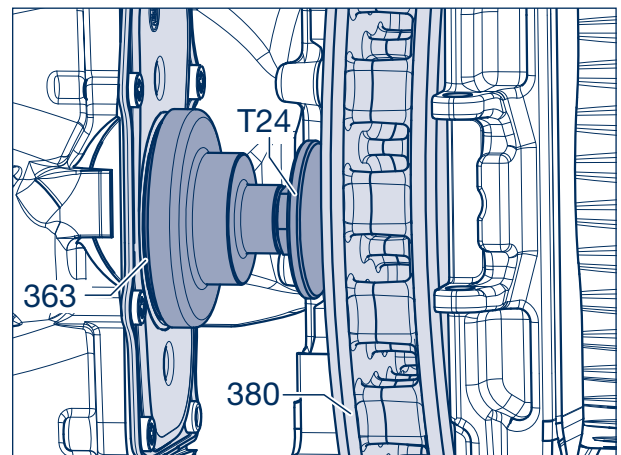

Figure 4

### Bellow assembly with the brake removed

- [5] Insert the assembly tool with bellow (363) into the brake caliper.
- [6] Center the bellow in the holder in the dust cover.
- [7] Slightly unscrew the spacer (T24) from the piston (T22) and the screw (T23) from the spacer, and use the opposite side of the brake lining shaft as a stop for pressing in.

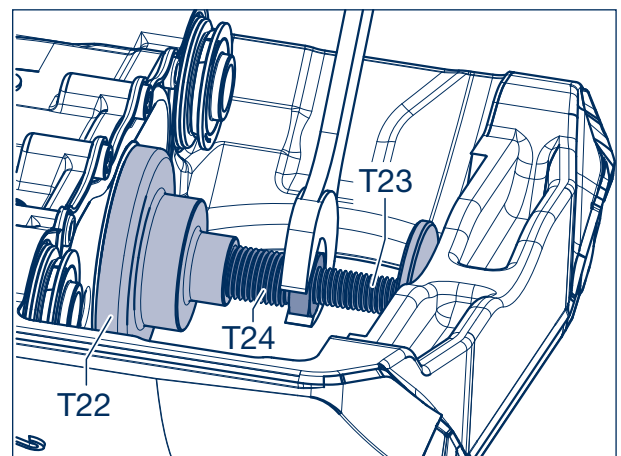

Figure 5

- [8] Use a spanner AF 24 to unscrew the spacer and press in the bellow until it stops.



**Repair note!**

The grooved bellow seat must be completely assembled in the dust cover, the gap between the piston and the bead of the dust cover is  $< 0.7$  mm (arrow). Make sure that the seating is entirely straight.

- [9] Screw in the spacer and remove the assembly tool.
- [10] Fit the brake linings and adjust the clearance; see chapter 8.

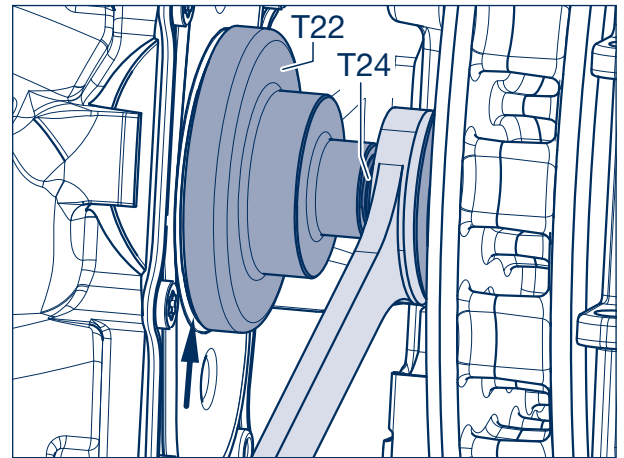

Figure 6

# 11 Overhauling the brake caliper guide

## 11.1 Replacing the bellow (fixed and floating bearing)

- [1] Dismantle the brake caliper, see chapter 9.
- [2] Remove the rings (356) from the guide pins (326, 346) or bellows (354).

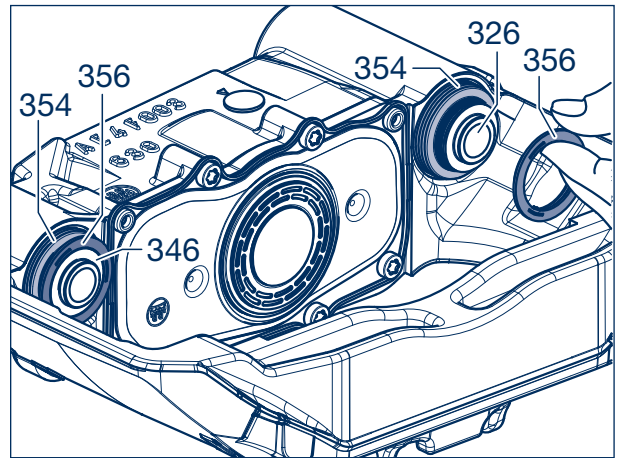

Figure 1

- [3] Pull out the guide pins (326, 346).

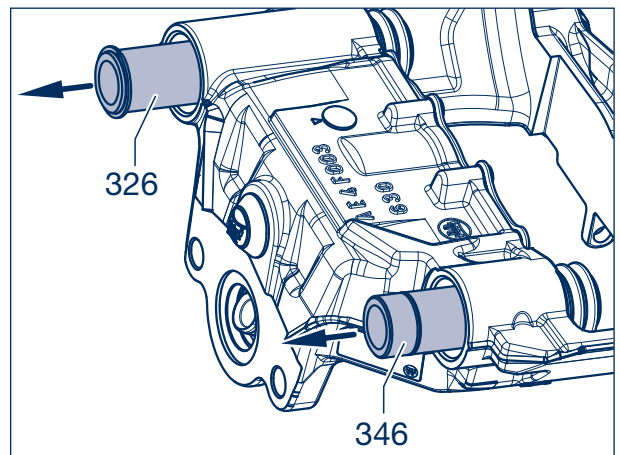

Figure 2

- [4] Lever out the bellows (354) with a screwdriver.



**Repair note!**

The seal seats of the bellows (354) in the brake caliper must not be damaged.

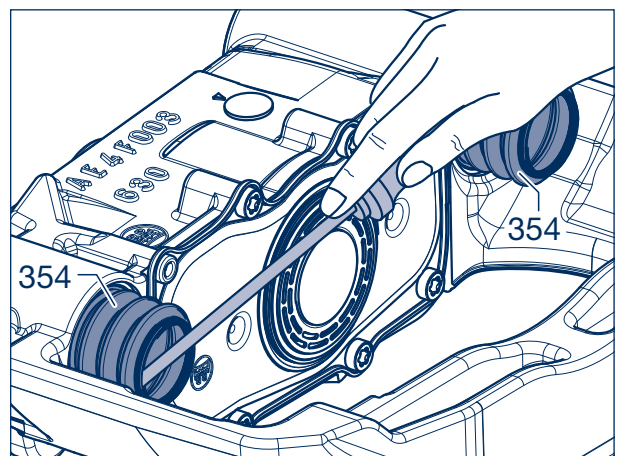



Figure 3

- [5] Check the seal seats in the brake caliper and the guide bushes (328, 348) for corrosion, dirt and damage, and replace them if necessary.

-  For installation of the bellows, see page 40, starting from working step [34].

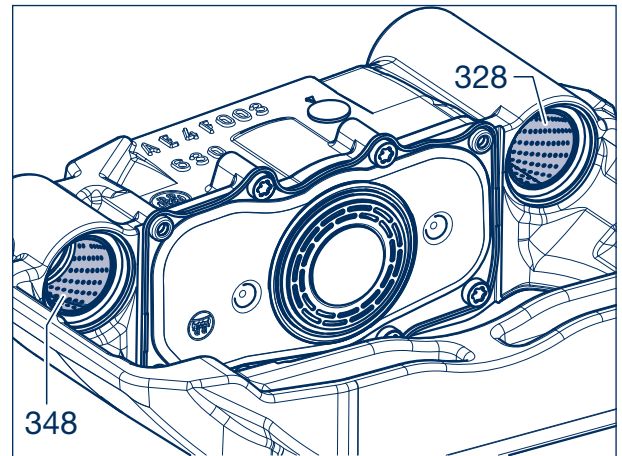

Figure 4

## 11.2 Replacing the guide bushes

- [6] To prevent accidents, position the brake caliper in a vice and fasten it to the outer bar. Ensure that the contact surfaces of the brake linings do not become damaged and use braces if necessary.
- [7] Clean the contact surfaces for the insertion / removal tool and the guide bushes (328, 348).

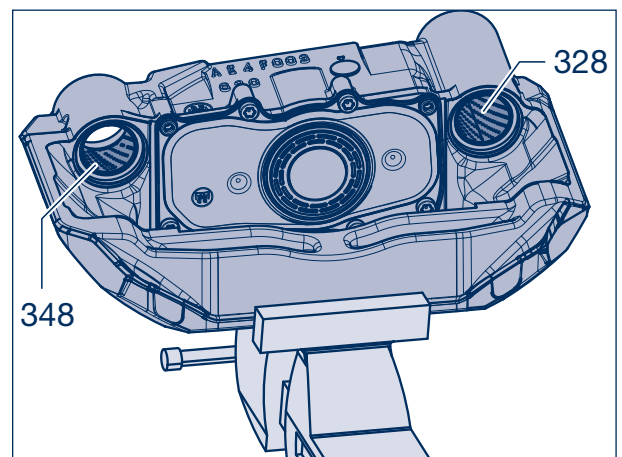

Figure 5

### Floating bearing 2 (short guide pin)

#### Extraction

- [8] Slide the ball bearing (T2) and the sleeve (T3) onto the threaded spindle (T1).
- [9] Guide the tool into the bearing from the outer side.

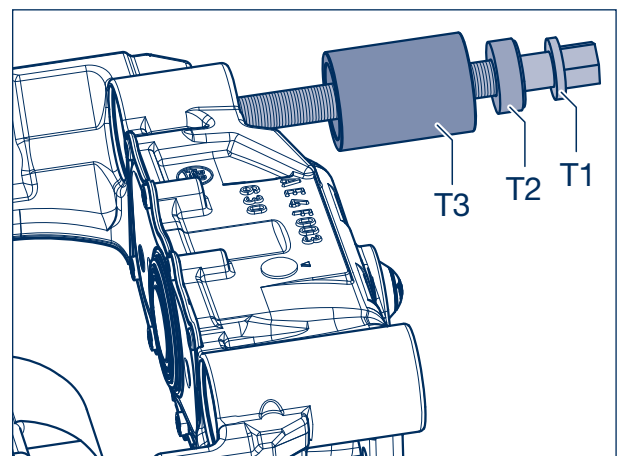

Figure 6

# 11 Overhauling the brake caliper guide

- [10] Connect the extraction tool (T4) and insert it into the guide bush (348, see figures 4 and 5).
- [11] Screw on the nut (T6) up to the stop point.
- [12] Turn the threaded spindle (T1) to pull the guide bush (348) out of the bearing. If necessary, brace the nut (T6) with an AF 32 spanner.
- [13] Clean the bearing seats.



**Repair note!**  
The bearing bore must be clean and free of grease.

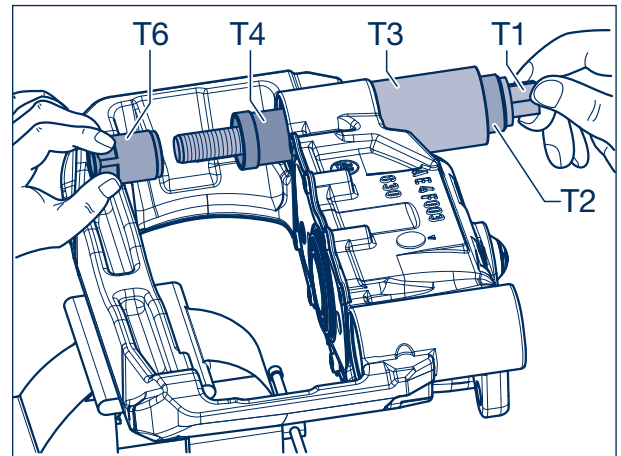

Figure 7

## Fixed bearing 1 (long guide pin)

### Extraction

- [14] Slide the ball bearing (T2) and the sleeve (T3) onto the threaded spindle (T1).
- [15] Guide the tool into the bearing from the outside.

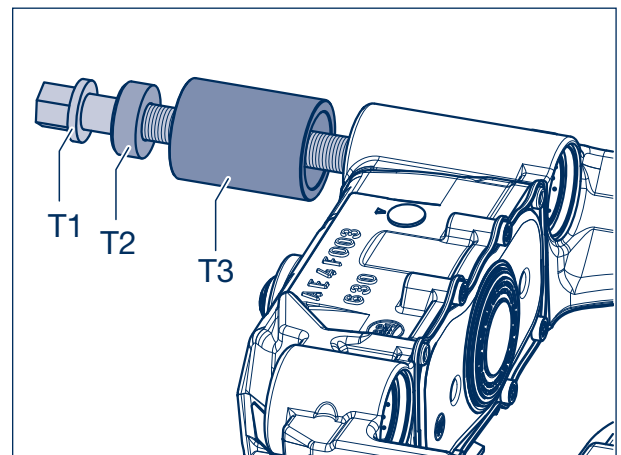

Figure 8

- [16] Connect the extraction tool (T4) and push it into the guide bush (328, see figures 4 and 5).
- [17] Screw on the nut (T6) up to the stop point.
- [18] Turn the threaded spindle (T1) to pull the guide bush (328) out of the bearing. If necessary, brace the nut (T6) with an AF 32 spanner.
- [19] Clean the bearing seats.



**Repair note!**  
The bearing bore must be clean and free of grease.

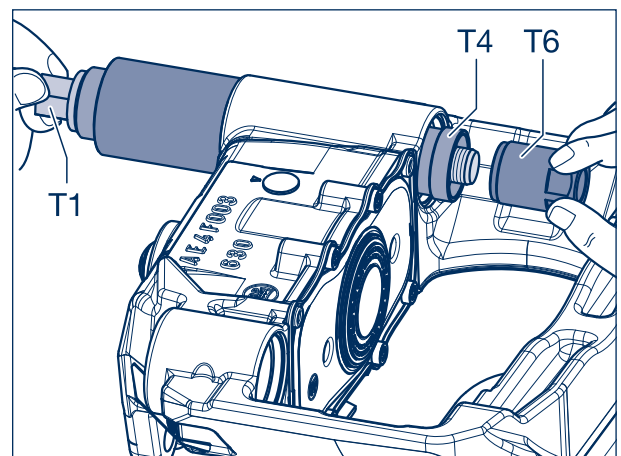

Figure 9



### Floating bearing 2 (short guide pin)

#### Pressing in

- [20] Slide the ball bearing (T2), the extraction tool (T4), and the pressing tool for the floating bearing (T21) onto the threaded spindle (T1).
- [21] Slide the new guide bush (348) onto the pressing tool (T21) for the floating bearing.
- [22] Insert the tool into the bore hole for the guide bush.

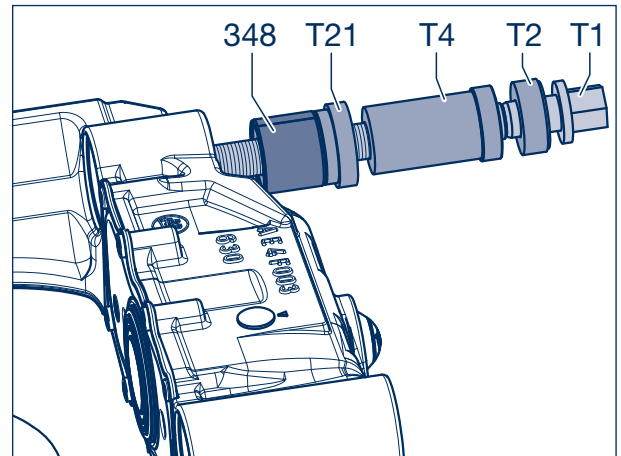

Figure 10

- [23] Slide the retraction plate (T20) onto the threaded spindle (T1) until it makes contact with the brake caliper. The chamfer must be guided into the bore hole on the brake caliper and the contact surface must lie flat.
- [24] Screw on the nut (T6) while ensuring that the retraction plate (T20) is properly seated.
- [25] Turn the threaded spindle (T1) up to the stop point to pull the guide bush (348) into the bore hole. If necessary, brace the nut (T6) with an AF 32 spanner.
- [26] Unscrew the nut (T6) and remove the tool.

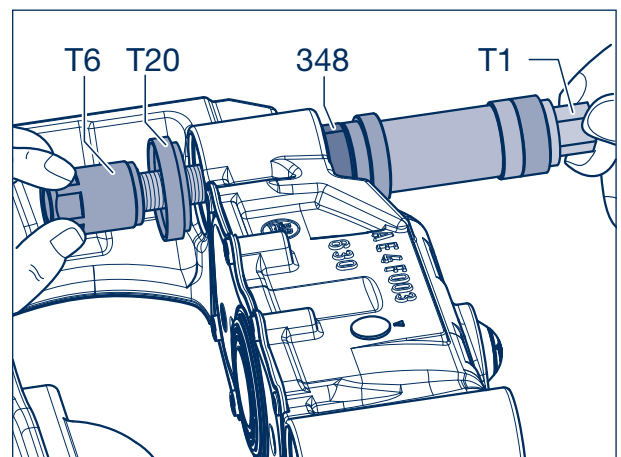

Figure 11

### Fixed bearing 1 (long guide pin)

#### Pressing in

- [27] Slide the ball bearing (T2) and the pressing tool for the fixed guide pin (T8) onto the threaded spindle (T1).
- [28] Push the new guide bush (328) in the correct position onto the pressing tool for the fixed bearing (T8).
- [29] Insert the tool into the bore hole for the guide bush.

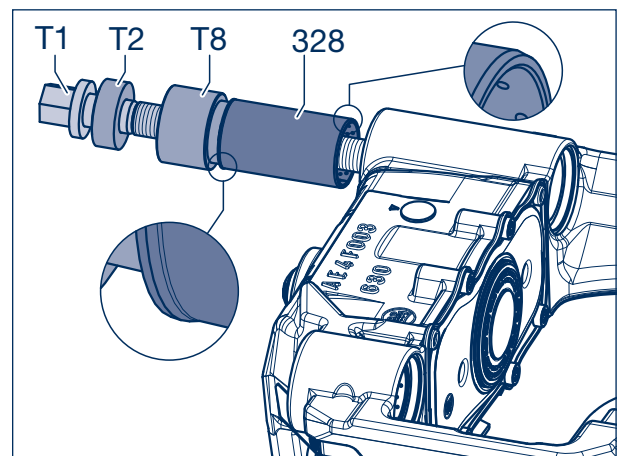

Figure 12

# 11 Overhauling the brake caliper guide

- [30] Slide the retraction plate (T20) onto the threaded spindle (T1) up to the brake caliper. The chamfer must be guided into the bore hole on the brake caliper and contact with a flush fit.
- [31] Screw on the nut (T6) while ensuring that the retraction plate (T20) is properly seated.
- [32] Turn the threaded spindle (T1) up to the stop point to pull the guide bush (328) into the bearing. If necessary, brace the nut (T6) with an AF 32 spanner.
- [33] Unscrew the nut (T6) and remove the tool.

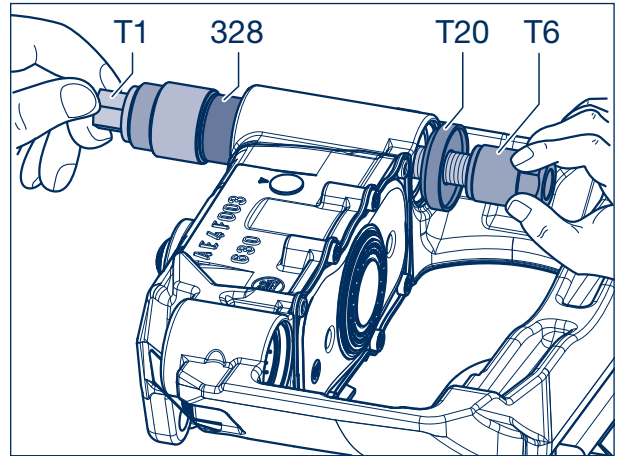

Figure 13

- [34] Insert the new bellows (354) and press them all the way into the caliper housing.



**Repair note!**  
The bellow seat in the brake caliper must be clean and free from grease.

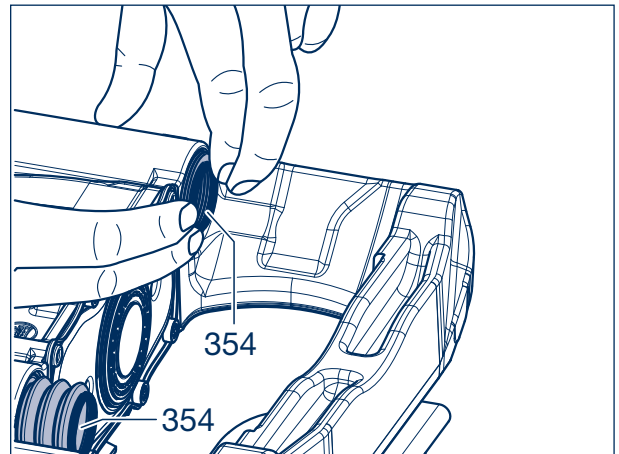

Figure 14

- [35] Make sure the bellows (354) are correctly seated. Pull to test.

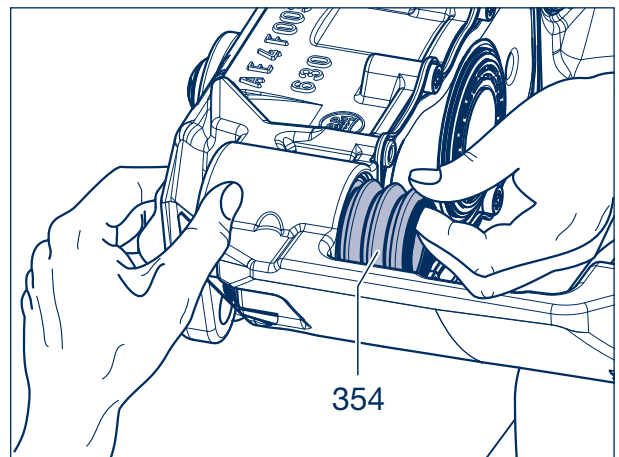

Figure 15



- [36] Insert an O-ring (355) into the groove (arrow) of the floating guide pin.
- [37] Apply **BPW ECO Disc Grease** to the guide bushes (328, 348) and O-ring (355).
- [38] Install the guide pins (326, 346).

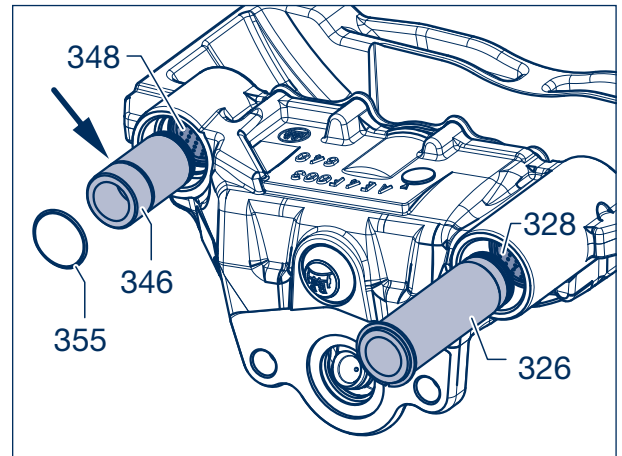

Figure 16

- [39] Insert the bellows (354) into the groove in the guide pins (326, 346, arrow).

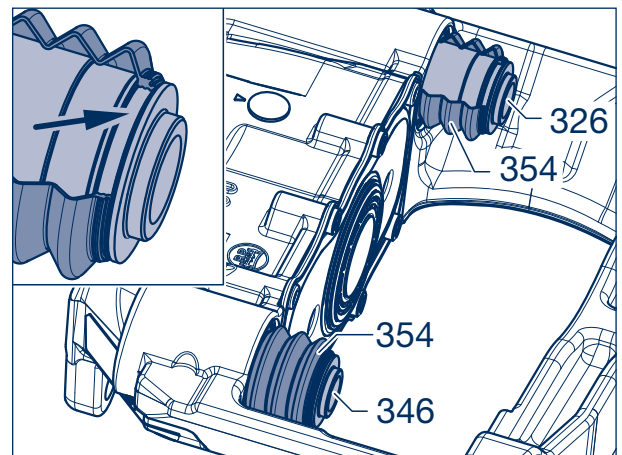

Figure 17

- [40] Push on the ring (356) to secure the bellow (354) in the groove of the guide pins (326, 346).



**Note!**  
Check the guide pins (326, 346) for ease of movement before installing the brake.

- [41] Install the brake caliper (see chapter 9.2).

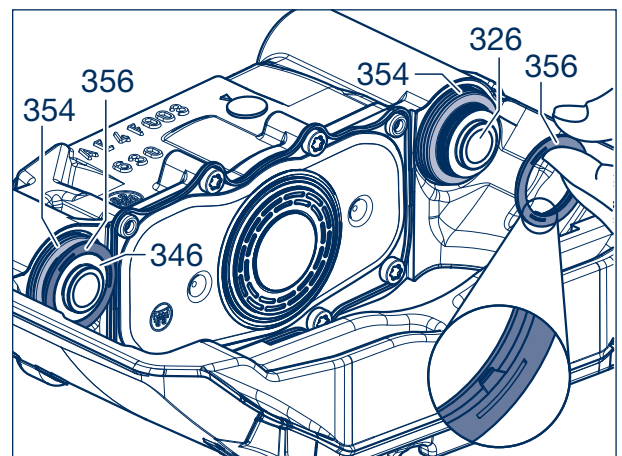

Figure 18

## 12 Disassembling / assembling the brake cylinders

### 12.1 Disassembling the spring brake cylinders



**Warning!**  
Before loosening the spring brake cylinders, secure the vehicle against rolling away.

- [1] Release the parking brake (hand brake valve).
- [2] Remove the lock (1) from the bore hole.

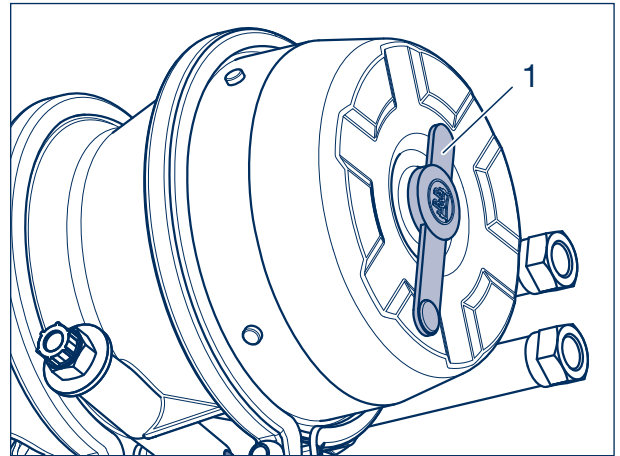

Figure 1

- [3] Remove the protective cap with thread (2), unscrew the nut (3) from the spindle (4) and remove it with the washer (5).

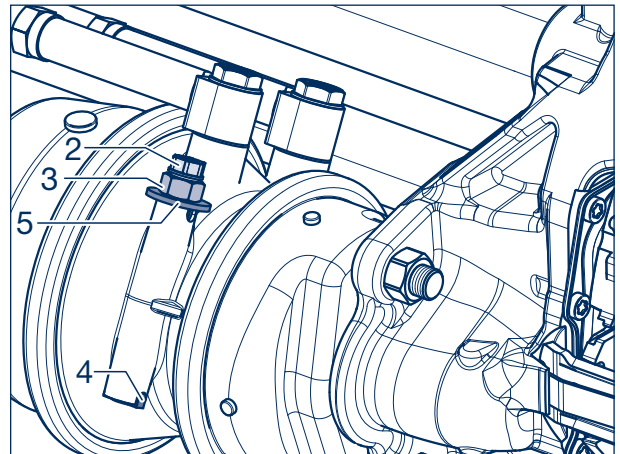

Figure 2

- [4] Insert the threaded spindle (4) into the brake cylinder (410, 411) and turn it 90° to engage.
- [5] Screw on the nut (3) and a washer (5). Tightening the nut causes the brake cylinder to be mechanically released.

With diaphragm piston type cylinders, unscrew and remove the spring brake bolt (mechanical release device / arrow) by turning it anticlockwise.



**Warning!**  
**DANGER OF INJURY!**  
Do not use an impact wrench.  
Brake cylinders must not be opened.

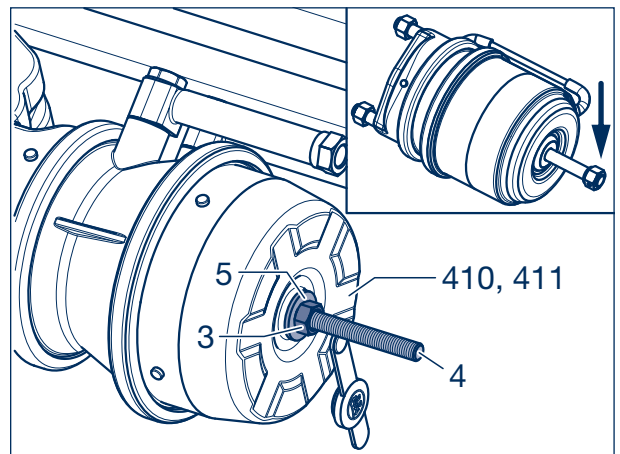

Figure 3

- [6] Mark air connections for proper installation and unscrew them from the brake cylinder (410, 411).
- [7] Loosen both attachment nuts (6) M 16 x 1.5 - AF 24 on the housing of the brake.
- [8] Remove the brake cylinder (410, 411).

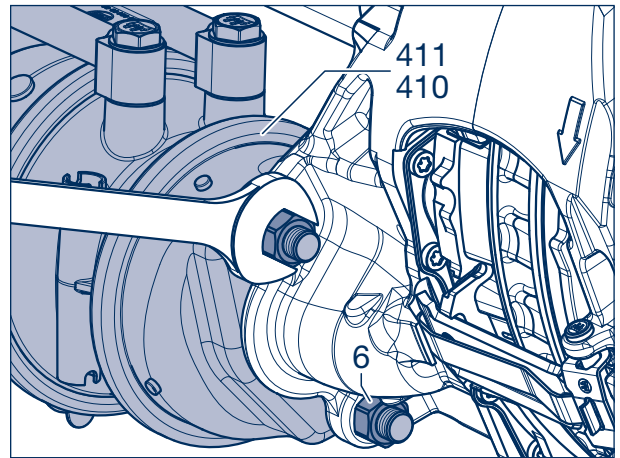

Figure 4

## 12.2 Assembling the spring brake cylinder



### **Caution!**

Only vent the spring brake cylinder at connection 1.1. (service brake) when it is mounted on the brake!



### **Note!**

When new brake calipers are used, the plug must be removed! Using a thin screwdriver, pierce the plug in the middle and lever the cap out of the brake caliper.

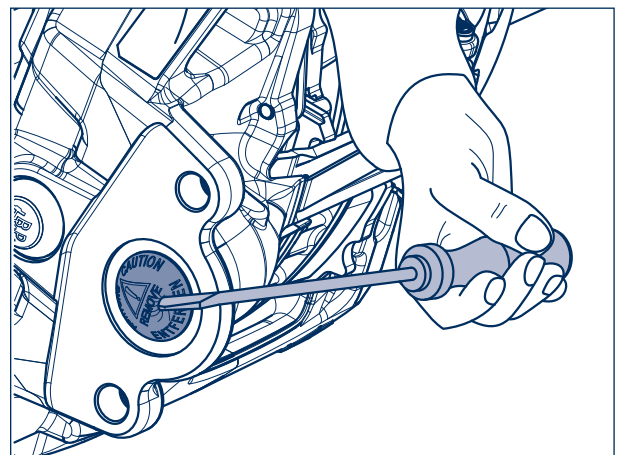

Figure 5



### **Note!**

Clean the housing and brake cylinder contact surfaces before fitting. The seal (1) and push rod chamber (2) of the brake cylinder (410, 411) must be free of dirt and moisture.



### **Repair note!**

Use only brake cylinders that are approved for disc brakes (with "inner sealing")!  
(See BPW-TE 2342.0)

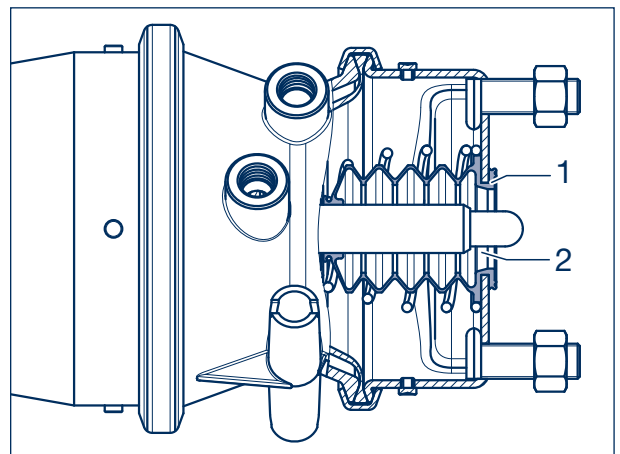

Figure 6

## 13 Disassembling / assembling the brake cylinders

- [9] Before inserting the new brake cylinder (410, 411), grease the spherical cap in the lever (arrow) with **BPW ECO Disc Grease Plus**.



**Repair note!**  
Do not use grease containing molybdenum disulphide!

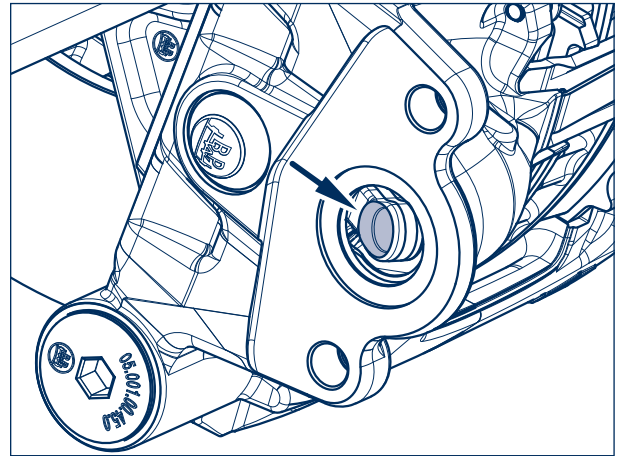

Figure 7

- [10] Position the brake cylinder (410, 411) and install it using new attachment nuts (6).  
Tightening torque:  
M 16 x 1.5 - AF 24      M = **180 Nm** (180 - 210 Nm)

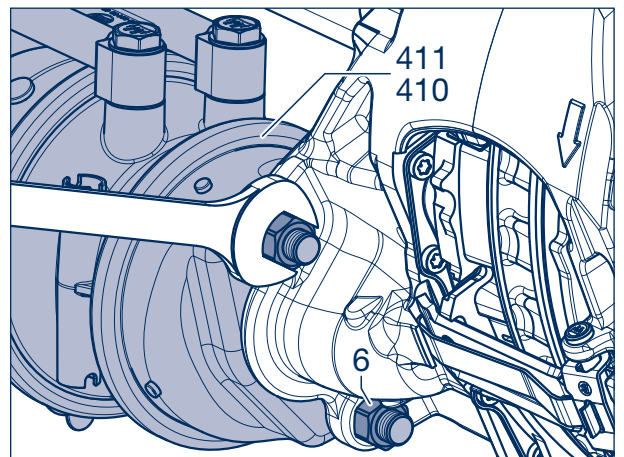

Figure 8

- [11] Remove both plugs (arrows) from the deepest drain holes of the new brake cylinder (410, 411). All other vent holes must remain sealed.
- [12] Connect the brake lines (air connections) and check the sealing. The brake lines must be routed such that they do not twist or can rub against other components.



**Repair note!**  
When connecting the compressed air lines to the brake cylinder, make sure the movement of the brake caliper is not obstructed by any adjacent components.

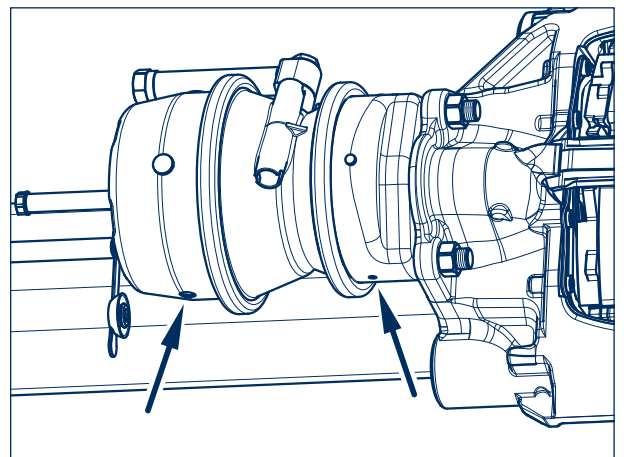

Figure 9



**Repair note!**  
Do not mix up the lines!

- [13] Release the parking brake by venting compressed air connection 1.2 with at least 6 bar.  
Loosen and unscrew the nut (3) on the spindle (4).
- [14] Remove the washer (5) from the spindle (4).
- [15] Turn the spindle (4) 90° and remove it from the brake cylinder (410, 411).

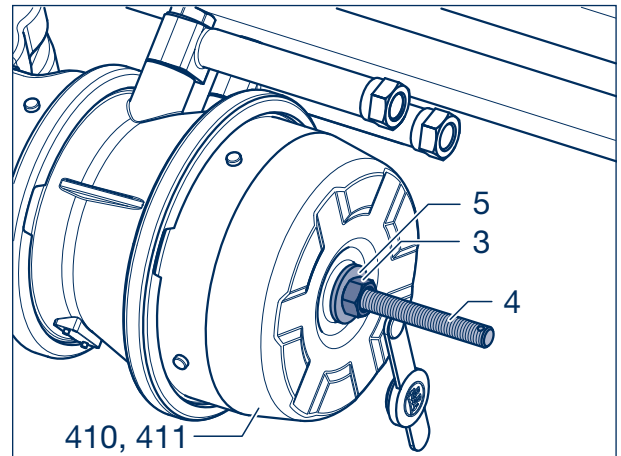

Figure 10

- [16] Close the bore hole with the lock (1) and fit the spindle (4) with the nut (3) and a washer (5) onto the brake cylinder (410, 411).
- [17] Screw on the protective cap with thread (2).

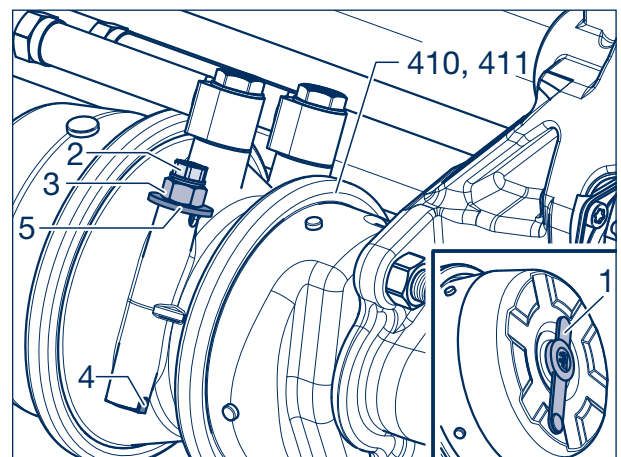

Figure 11

With diaphragm piston type cylinders, screw in the spring brake bolt up to the stop and tighten it.  
Tightening torque:  
M = **40 Nm** (30 - 50 Nm).



**Warning!**  
The spring-loaded brake does not function if the spring brake screw is not screwed in.



**Repair note!**  
Check the functioning and effectiveness of the brake system!

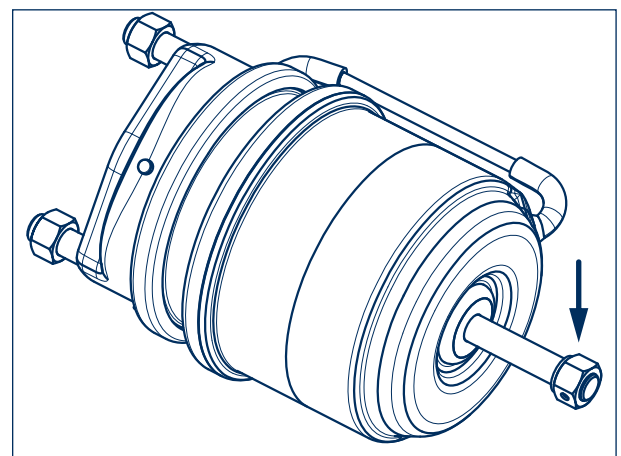
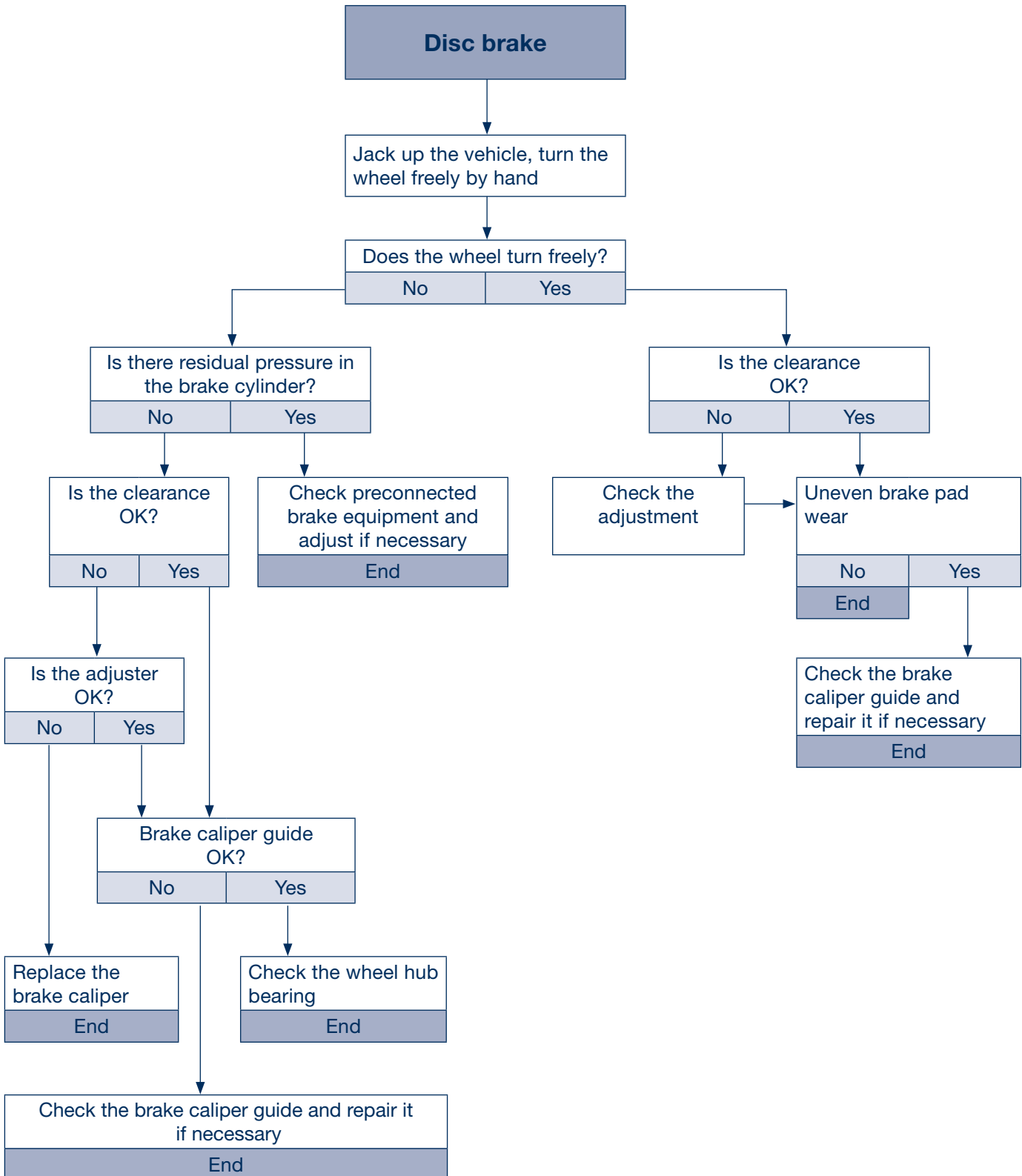

Figure 12



# 14 Troubleshooting





---

# Notice

BPW is a globally leading manufacturer of intelligent running gear systems for trailers and semi-trailers. As an international mobility and system partner, we offer a wide range of solutions for the transport industry from a single source, from axle to suspension and brake to user-friendly telematics applications.

We thereby ensure outstanding transparency in loading and transport processes and facilitate efficient fleet management. Today, the well-established brand represents an international corporation with a wide product and service portfolio for the commercial vehicle industry. Offering running gear systems, telematics, lighting systems, composite solutions and trailer superstructures, BPW is the right system partner for automotive manufacturers.

BPW, the owner-operated company, consistently pursues one target: To always give you exactly the solution which will pay off. To this end, we focus our attention on uncompromising quality for high reliability and service life, weight and time-saving concepts for low operating and maintenance costs as well as personal customer service and a close-knit service network for quick and direct support. You can be sure that with your international mobility partner BPW, you always use the most efficient method.

# Your partner on the economically viable path!



**BPW Bergische Achsen Kommanditgesellschaft**

Postbox 12 80 · 51656 Wiehl, Germany · Phone +49 (0) 2262 78-0  
info@bpw.de · [www.bpw.de](http://www.bpw.de)